

A modular design for the 56 variants of the short straight section in the arcs of the Large Hadron Collider (LHC)

J-B. Bergot, P. Dambre, L. Nielsen, V. Parma, M. Peyrot, T. Renaglia, J-M. Rifflet, P. Rohmig, E. Roy, F. Simon, et al.

► **To cite this version:**

J-B. Bergot, P. Dambre, L. Nielsen, V. Parma, M. Peyrot, et al.. A modular design for the 56 variants of the short straight section in the arcs of the Large Hadron Collider (LHC). European Particle Accelerator Conference 7, Jun 2000, Vienne, Austria. pp.3. in2p3-00018169

HAL Id: in2p3-00018169

<http://hal.in2p3.fr/in2p3-00018169>

Submitted on 27 Nov 2000

HAL is a multi-disciplinary open access archive for the deposit and dissemination of scientific research documents, whether they are published or not. The documents may come from teaching and research institutions in France or abroad, or from public or private research centers.

L'archive ouverte pluridisciplinaire **HAL**, est destinée au dépôt et à la diffusion de documents scientifiques de niveau recherche, publiés ou non, émanant des établissements d'enseignement et de recherche français ou étrangers, des laboratoires publics ou privés.



**A MODULAR DESIGN FOR THE 56 VARIANTS
OF THE SHORT STRAIGHT SECTION IN THE ARCS
OF THE LARGE HADRON COLLIDER (LHC)**

J-B. Bergot¹, Ph. Dambre¹, L. Nielsen², V. Parma², M. Peyrot³, T. Renaglia²,
J-M. Rifflet³, P. Rohmig², E. Roy¹, F. Simon³, T. Tortschanoff² and D. Vincent¹

Abstract

The 360 Short Straight Sections (SSS) necessary for the eight arcs of the LHC machine have to fulfil different requirements. Their main function is to house the lattice two-in-one superconducting quadrupole and various correction magnets, all operating at 1.9 K in a superfluid helium bath. The magnetic and powering schemes of the arcs and the fact that the two proton beams alternate between the inner and outer magnet channels impose 24 different combinations of magnet assemblies, all housed in an identical helium enclosure. The cryogenic architecture of the LHC machine is based on cryogenic loops spanning over one half-cell (53 m) for the 4.6-20 K circuit, over a full cell (107 m) for the 1.9 K circuits, up to the full arc (about 2.3 km) for the shield cooling line. This cryogenic layout, when superimposed to the magnetic scheme, further complicated by the cryostat insulation vacuum sectorisation every 2 cells, creates additional assembly variants, up to a total number of 56. The required flexibility in the manufacture and assembly, as well as economic considerations, have led to a modular design for the different SSS components and sub-assemblies. This modularity allows to "specialise" the SSS at the latest possible assembly step of the "just in time" production line. This paper presents the conceptual design considerations to achieve this modularity, the SSS design retained for the series manufacture, and the assembly procedures recently validated on a prototype program at CERN.

1 IPNO, Orsay, France. Member of the CERN-CEA-IN2P3 Collaboration to the LHC Project

2 CERN, LHC Division, Geneva, Switzerland

3 CEA, Saclay, France. Member of the CERN-CEA-IN2P3 Collaboration to the LHC Project

Presented at the Seventh European Particle Accelerator Conference (EPAC 2000)
26-30 June 2000, Vienna, Austria

A MODULAR DESIGN FOR THE 56 VARIANTS OF THE SHORT STRAIGHT SECTION IN THE ARCS OF THE LARGE HADRON COLLIDER (LHC)

L. Nielsen, V. Parma, T. Renaglia, P. Rohmig, T. Tortschanoff, CERN, Geneva, Switzerland
J-B. Bergot, Ph. Dambre, E. Roy, D. Vincent, IPNO, Orsay, France
M. Peyrot, J-M. Rifflet, F. Simon, CEA, Saclay, France

Abstract

The 360 Short Straight Sections (SSS) necessary for the eight arcs of the LHC machine have to fulfil different requirements.

Their main function is to house the lattice two-in-one superconducting quadrupole and various correction magnets, all operating at 1.9 K in a superfluid helium bath.

The magnetic and powering schemes of the arcs and the fact that the two proton beams alternate between the inner and outer magnet channels impose 24 different combinations of magnet assemblies, all housed in an identical helium enclosure.

The cryogenic architecture of the LHC machine is based on cryogenic loops spanning over one half-cell (53 m) for the 4.6-20 K circuit, over a full cell (107 m) for the 1.9 K circuits, up to the full arc (about 2.3 km) for the shield cooling line.

This cryogenic layout, when superimposed to the magnetic scheme, further complicated by the cryostat insulation vacuum sectorisation every 2 cells, creates additional assembly variants, up to a total number of 56.

The required flexibility in the manufacture and assembly, as well as economic considerations, have led to a modular design for the different SSS components and sub-assemblies. This modularity allows to “specialise” the SSS at the latest possible assembly step of the “just in time” production line.

This paper presents the conceptual design considerations to achieve this modularity, the SSS design retained for the series manufacture, and the assembly procedures recently validated on a prototype program at CERN.

1 INTRODUCTION

The eight arcs of the LHC lattice contain 360 SSS, one in every 53 m long half-cell.

A SSS consists of a twin-aperture high-gradient superconducting quadrupole (MQ) and two pairs of superconducting corrector magnets, operating in pressurized helium II at 1.9 K. The magnets together with their dedicated bus bars and the MQ protection diode are housed in a helium vessel, thus constituting the so-called cold mass.

The cryostat of the SSS consists of two main parts: the standard cryostat section constituting the cryostat envelope of the cold mass and the Technical Service Module (QSS). The latter houses the Beam Position Monitor (BPM), instrumentation and dipole corrector feed-throughs and, depending on the variants, an insulation vacuum barrier, the cryogenic interconnects to the LHC Cryogenic Distribution Line (QRL) and a helium phase separator [1] (Fig. 1).

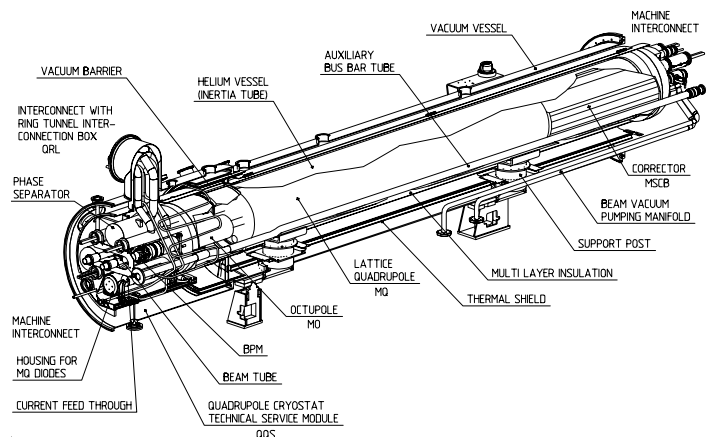

Figure 1: Layout of a LHC arc Short Straight Section

To cope with the variety of magnet combinations imposed by the magnetic and powering schemes [2] required by the proton beams alternating between the inner and outer magnet channel, and the further complexity introduced by the cryogenic [3] and insulation vacuum sectorisation layout, a modular design has been developed.

Furthermore, the design had to take into account the specific requirements of the cold testing and assembly activities to be carried out on the SSS before their final installation in the LHC (e.g. the BPM and beam screen installed after the cold tests at CERN).

The aim of this modular approach was to simplify and to standardise the components and to configure the variants only during SSS assembly. Another target was to specialise the units only at the latest possible stage such reducing further the number of different sub-assemblies permitting a “just in time” production.

The following chapters describe the modular design retained.

2 MODULAR DESIGN OF THE SSS

2.1 General

The design of the SSS was split into 2 design packages: the cold mass and the standard cryostat section with the QQS. The different technological specificities of these two packages entail naturally two different contracts. Therefore, the design takes into account the necessity to simplify and clearly identify the interfaces.

2.2 Cold mass

Two different corrector magnet modules are situated on each side of the quadrupole:

- A twin-aperture Sextupole-Dipole corrector (MSCBA/B) or a Skew Sextupole-Dipole corrector (MSCBC/D) on the right side of the MQ.
- A pair of Octupole (MO), or Tuning Quadrupole (MQT), or Skew Quadrupole (MQS) corrector magnets on the left side of the MQ.

The design choice of positioning and fixing the magnets by fitting keys inside a common inertia tube, which allows the modular assembly of the magnet modules, was already successfully applied by CEA on the quadrupoles for the HERA machine.

To ease the assembly of the MO, MQT or MQS corrector pairs inside the cold mass, the correctors have all the same geometrical length and they are pre-assembled in a support structure having an identical interface to the inertia tube.

The MSCBA/B or MSCBC/D corrector magnets have all the same yoke structure. Only the coils, identical in geometry, are assembled in order to yield the wanted magnetic scheme (e.g. vertical or horizontal dipole orientation).

Two bus-bar circuits with two different MQ connections define the focusing or defocusing polarity of the magnets. SSS at locations of sectorisation points of the arc, one out of four, have flow restriction plugs integrated in the bus bars, which are sealed during cold mass assembly to the front cover bus-bar tubes.

The two types of MQ protection diode assemblies, having a common mechanical heat sink design, differ only by the diode orientation, dictated by the LHC powering scheme. Diode packs are installed in easily accessible appendices of the cold mass on the left interconnection side. This allows late SSS final specialisation in the assembly process, and easy replacement in case of failure in the LHC machine.

All other mechanical components of the cold mass such as the inertia tube with its right end cover equipped with expansion bellows, the cold bores, the helium heat exchanger tube are of identical design. If the SSS includes an insulation vacuum barrier, a welding seam is added onto the inertia tube, introducing an exception in the standardisation of this component.

The superposition of the different magnetic, powering and cryogenic schemes of the LHC leads to a total of 24 different magnet combinations and in total 40 different cold mass variants. The final cold mass variant is obtained through procedures applied on a vertical assembly set-up. The prototype program [4], carried out at CEA-Saclay and CERN in 1999 and completed in Spring 2000, confirmed the validity of the modular design and assembly, summarized in Table 1 below.

Table 1: SSS cold mass modular design, shown in the assembly flow chart

Modular components	No. of component variants	Specialisation requirements	Cold mass variants for LHC
MO, MQT, MQS	3	MO, MQT, MQS correctors	3
MQ	1	MO, MQT, MQS with MQ	3
MSCBA/B, MSCBC/D	4	Magnets scheme	8
Bus-bar circuits (pressure restrict. plugs)	2 (+ 2)	Magnetic and electric circuits	14
Inertia tube type S, V	2	Cold mass and vac. sectorisation	14
Front cover type A, B, Z	3	Cold mass and cryogenic layout	20
MQ diode type A, B	2	Magnetic circuits polarity	40

2.3 Cryostat and QQS

The standard cryostat section incorporates the same design feature as the LHC arc dipole cryostats. All its components are identical throughout the 56 SSS variants except for the 50-65 K thermal shield system and its multilayer insulation blankets, manufactured in two different parts when an insulation vacuum barrier is integrated in the SSS.

The Technical Service Module (QQS), of a unique length, has to satisfy the cryogenic feeding requirements of the LHC. In addition to the BPM, Instrumentation feed-through System (IFS) and dipole corrector feed-throughs, which are identical for all SSS, it houses four different cryogenic circuits, yielding six different QQS assemblies:

- The 4.6-20 K cooling circuit of the beam screen and support posts connected to the QRL at each half-cell.
- The 1.8 K sub-cooling circuit connecting the QRL through the helium phase separator feeding the cold masses of one cell.
- The circuit for the filling and quench recovery line connection of two cells, separated by the flow restriction plugs in the bus-bar interconnect tubes, between cold masses.
- The 50-65 K cooling line of the thermal shield system connected in series over a full machine arc of about 2.3 km.

All cryogenic circuits linking the machine cryostat to the cryogenic distribution line QRL are connected via a so-called “jumper”. Designed following the modularity principle, the cryogenic tubing is assembled in the same jumper vacuum vessel and thermal shield, according to the six QQS variants.

Due to the inclination of the LHC machine tunnel plane of 1.4 % and the requirements for an up-slope feeding, two connection types of the same modular helium phase separator are required, depending on the position of the SSS in the tunnel.

Identical modular components are used up to the welding of the end covers of the enclosure (Fig. 2).

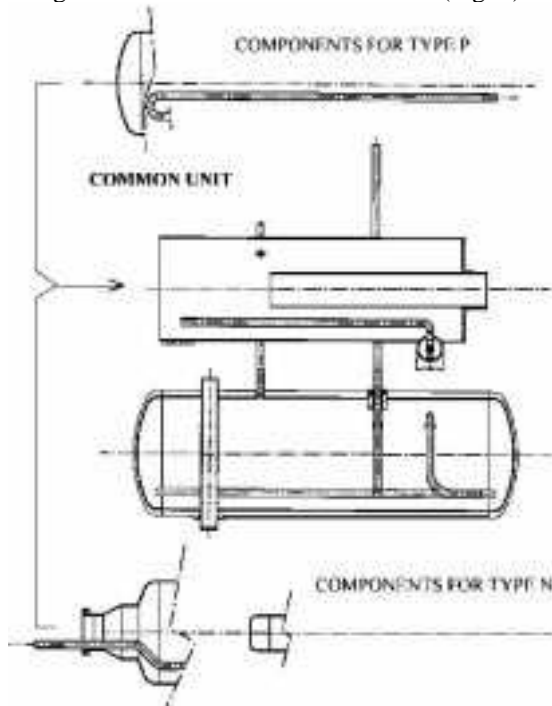

Figure 2: SSS helium phase separator modular design

The evolution of the number of SSS variants in the assembly line process is summarised in Table 2.

Table 2: SSS cryostat configurations, shown in the assembly flow line

Modular components	No. of component variants	Specialisation requirements	SSS variants for LHC
Cold mass	40	As supplied by the contractor	40
Standard cryostat section type V, S	2	Vacuum sectorisation	40
He phase separator type P, N, F	3	Jumper type, tunnel position	56
Cryogenic tubing modules A, B, D, E, F, Z	6	Cryogenic scheme, and final SSS variant	56

3 SSS ASSEMBLY

The LHC require 40 different cold masses and with its cryostats a total of 56 SSS variants are needed. As shown in Tables 1 and 2 special care has been taken to specialise the SSS at the latest possible stage of assembly. In spite of this approach and in view of their distribution [5] around the LHC and of the required installation sequence on two installation fronts, the SSS manufacture and assembly, split in two contracts, entail a “just in time” production rate and a dedicated logistic management.

4 CONCLUSIONS

Two SSS prototypes were built following the modular design described herein. One features the most complex SSS, the other one a simpler variant which covers 50 % of the LHC units. The cold masses were built at CEA-Saclay and assembled afterwards in their cryostats at CERN. Both prototypes confirmed the modular design chosen and are actually undergoing successfully cold measurements.

5 ACKNOWLEDGMENTS

The authors wish to thank the members of the SSS Working Group at CERN and the design teams in the three institutes participating on the LHC-SSS project.

REFERENCES

- [1] W. Cameron et al. “The new superfluid helium cryostats for the Short Straight Sections of the CERN Large Hadron Collider (LHC)”, *Advances in Cryogenic Engineering*, Vol.43, 1998.
- [2] P. Burla “Powering Layout of the SSS Correction Scheme”, CERN Functional Specification LHC-DCC-ES-0003.00, May 2000, unpublished.
- [3] G. Riddone “Dimensions, Pressures, Temperatures and Sizing of Valves and Piping in the LHC Machine Cryostat and Cryogenic Distribution Line”, CERN Engineering Specification LHC-Q-ES-0001.00, Sep. 1998, unpublished.
- [4] M. Peyrot et al. “Construction of the New Prototype of Main Quadrupole Cold Masses for the Arc `Short Straight Sections of the LHC”, *International Conference on Magnet Technology*, 1999.
- [5] L. Nielsen “Short Straight Section (SSS) types in the Arcs from Q12 to Q12”, CERN Engineering Specification LHC-LQA-ES-0004.00, Sept. 1999, unpublished.