



HAL
open science

Survey and alignment concept for installation of the SPIRAL2 accelerator devices at GANIL

R. Beunard

► **To cite this version:**

R. Beunard. Survey and alignment concept for installation of the SPIRAL2 accelerator devices at GANIL. 10th International Workshop on Accelerator Alignment, Feb 2008, Tsukuba, Japan. in2p3-00260260

HAL Id: in2p3-00260260

<https://hal.in2p3.fr/in2p3-00260260>

Submitted on 3 Mar 2008

HAL is a multi-disciplinary open access archive for the deposit and dissemination of scientific research documents, whether they are published or not. The documents may come from teaching and research institutions in France or abroad, or from public or private research centers.

L'archive ouverte pluridisciplinaire **HAL**, est destinée au dépôt et à la diffusion de documents scientifiques de niveau recherche, publiés ou non, émanant des établissements d'enseignement et de recherche français ou étrangers, des laboratoires publics ou privés.

SURVEY AND ALIGNMENT CONCEPT FOR INSTALLATION OF THE SPIRAL2 ACCELERATOR DEVICES AT GANIL*

R. Beunard, GANIL, BP 55027, 14076 CAEN, CEDEX 5, France

Abstract

The SPIRAL2** project located at the Grand Accélérateur National d'Ions Lourds (GANIL facility - Caen, France) has been studied since the beginning of 2001, and is now under construction (Fig. 1). This project aims at delivering energetic rare (radioactive) isotope beams with intensities not yet available with presently running machines. An important aspect of this project is that it will allow GANIL to deliver to users up to five different beams in parallel.

This paper is focused mainly on the survey and alignment techniques selected for the SPIRAL2 accelerator installation.

The survey procedures for the production of Radioactive Ion Beams (RIB) equipments such as plugs, separators and beam lines will be defined as soon as their alignment specifications will be known.

In such a project, the alignment aspects have to be studied very early. To determine the best technique for aligning any equipment, it is essential to know the precision required for the six degrees of freedom, and to understand the reasons for the requested precision. An object is "located" by its fiducial marks. The high quality of the mechanical connection to these marks is important for the final precision of the object location.

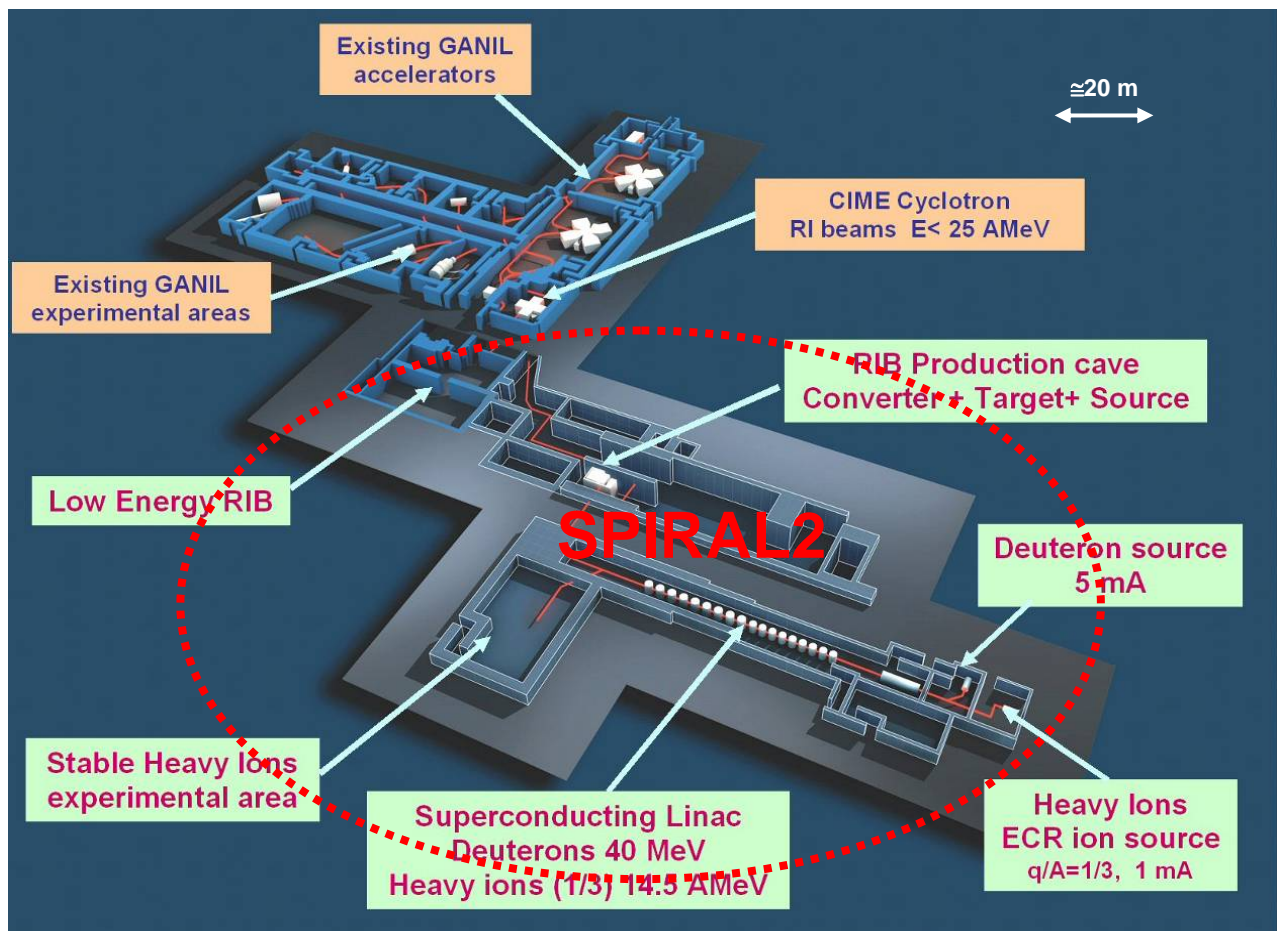

Figure 1 : Layout of the SPIRAL2 accelerator complex

* GANIL: Grand Accélérateur National d'Ions Lourds [Large-scale national accelerator for heavy ions]

** SPIRAL2 : Système de Production d'Ions Radioactifs Accélérés en Ligne [production system of on-line accelerated radioactive ions]

INTRODUCTION

SPiRAL2 is the project of a facility intended for the production of new beams of stable and radioactive ions at GANIL. The SPiRAL2 facility is based on a high-power superconducting driver LINAC which delivers a high-intensity, 40-MeV deuteron beam, as well as a variety of heavy-ion beams with mass-to-charge ratio equal to 3 and energy up to 14.5 MeV/u. The driver accelerator will send stable beams to a new experimental area and to a cave for the production of Radioactive Ion Beams (RIB). The commissioning of the driver should start in 2011 at GANIL.

Fast neutrons produced from the break-up of the 5 mA deuteron beam using a carbon converter will induce up to 10^{14} fissions/s in a uranium carbide target. The extracted RIB will subsequently be accelerated to energies up to 20 MeV/u (typically 6-7 MeV/u for fission fragments) by the existing CIME cyclotron.

The surveying and alignment activities at GANIL are under the responsibility of a two people team in the Physic Technical Department. The surveyor team supports and interacts with physicists and engineers working on any specific projects, from the detailed design study (APD), to the final alignment of components in the beam line.

This paper is focused mainly on the survey and alignment techniques selected for installation of the SPiRAL2 accelerator devices. We will also present the survey instruments which will be used for alignment.

GEODESIC NETWORK

An indispensable element of the survey is the geodesic network made up of a series of stable points at strategic locations. It defines the reference coordinates for the facility. In practice, only the radioactive beam lines need to be aligned with the GANIL geodesic network as reference. The accelerator can be aligned according to an independent network, the connection between the two systems being carried out at the position of the production target. In fact, it seems more convenient to use a unique geodesic network for the whole GANIL site. Moreover, this would also simplify connection of any future Linac extension to the GANIL experimental areas. The construction of such a network (floor and wall monuments) requires room, stability and optical visibility, which are not always easy to get because of the radioprotection shielding and the nuclear containment. The lack of a geodesic network outside the present buildings is also a drawback. Consequently, in the near future, the densification of the existing network towards the outside of building will become a necessity to ensure the setting up of the accelerator facility. This will consist, at first, in establishing a geodetic surface network made up of concrete monuments around the existing building. A simulation of the network will be carried out to study various configurations and to evaluate its performance.

A geodesic network allows one to locate the equipments with absolute coordinates. Sometimes the

position of a piece of equipment relative to the position of adjacent equipments can be sufficient, or even more efficient. In this case, all the equipment aligned relatively to others can still be aligned globally by referring its coordinates to the reference network.

Two potential technologies are investigated to measure geodesic network. The first one is a motorised theodolite. The second one is a fully automatic polar coordinates system (laser tracker). These two instruments are complementary, i.e. the theodolite provides a highest angular accuracy while the laser tracker gives an excellent distance precision.

ALIGNMENT STUDIES FOR THE SPiRAL2 DRIVER ACCELERATOR

The accelerator is composed of an injector, a superconducting linac and a high energy line. In the injector part, there is a deuteron line and a heavy-ion line (LEBT), a RFQ and a MEBT. Two kinds of superconducting cavity are used for the LINAC ($\beta=0.07$, $\beta=0.12$).

To determine the best technique for aligning any equipment, it is essential to know the precision required for the six degrees of freedom, and to understand the reasons for the requested precision. An object is "located" using its fiducial marks or reference mark. The high quality of the mechanical connection to these marks is important in the final precision of the object location. Numerous techniques can be used. However, if some equipment requires specific instrumentation and methods, most of them can be aligned with standardised means [1] [2].

SURVEY AND ALIGNMENT CONCEPT FOR INJECTOR BEAM LINES COMPONENTS

In a first stage, pending to have the new buildings on the GANIL site, the injector (Fig.2) will be both built and tested at the Saclay Laboratory (near Paris). First beams are scheduled for the middle of 2009.

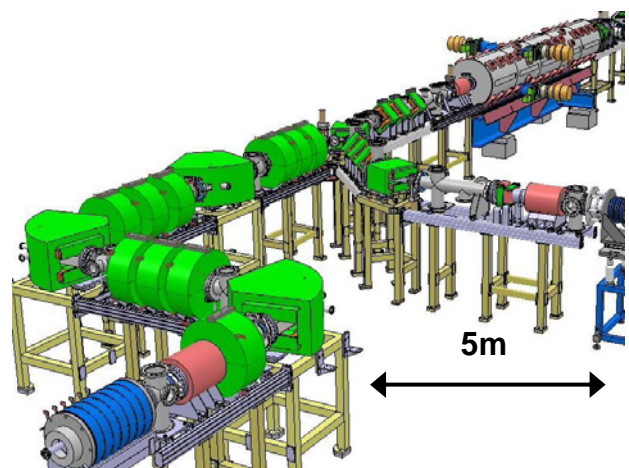

Figure 2: Layout of the injector beam lines

Alignment tolerances

The tolerated maximum static errors for the global alignment are :

- a) Both quadrupole and dipole magnets
 - Translation XY: $\pm 0.1\text{mm}$
 - Rotation (OX, OY): $\pm 0.1\text{deg}$
 - Rotation (Z): $\pm 0.1\text{deg}$
- b) Profiler Multiwire
 - Translation XY: $\pm 0.5\text{mm}$

Magnet fiducialization

The fiducials are the points located on the magnet with respect to the theoretical beam trajectory. For each element, a set of basic plates on the outside surface of the magnets will be determined with respect to the magnetic plane (Fig. 3). Regarding dipoles, three plates will be determined. As for the quadrupoles a basic rectangular plate is planned on the top of the magnet yoke on which two reference socket cups will be fixed. Its position on the magnet will be checked by optical measurements. During the alignment process, each magnet plate will be fiducialized with a reference socket cup (CERN-type).

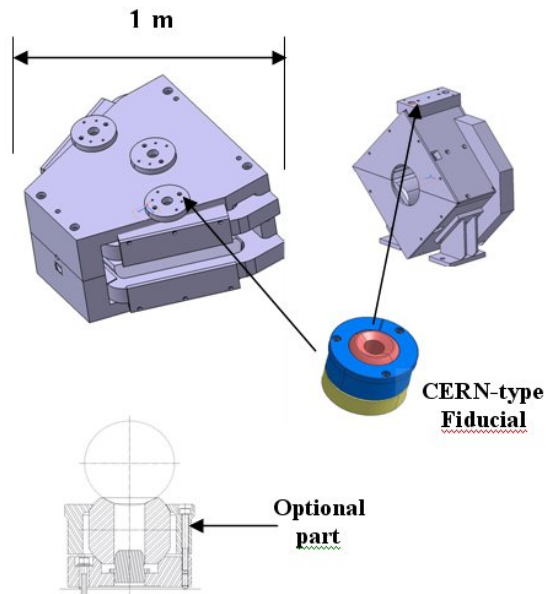

Figure 3: Magnets fiducialization

According to the need, one will use either the lower part of the socket cup equipped with devices like Taylor Hobson sphere, reflector, or the complete socket cup used for supporting instrumentation like a tacheometer. The socket cup will be centred on the basic plate.

The optical tooling techniques will be employed for the alignment first stage. For the final survey, all fiducials of the Injector beam lines components will be measured in the network with the Laser Tracker and digital levels.

Diagnostic boxes fiducialization

The diagnostic devices will be aligned on a bench before their installation on the beam lines. In order to drive the SPIRAL2 beam along the beam transport three kinds of beam profile monitor have been developed at Ganil:

- The multiwire beam monitors composed of a horizontal and a vertical grid of 47 golden tungsten wires of $150\ \mu\text{m}$ (Fig.4).
- The non-interceptive beam profile monitor.
- The low intensity beam profile monitor.

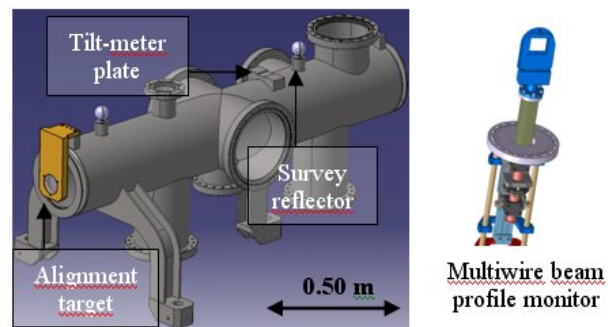

Figure 4: Diagnostic box fiducialization

First alignment

Prior to the alignment, both beam axis and all component frames will be marked on the floor. The frames will be adjusted compared with the beam axis using machined blocks. A Leica optical level will be used for this operation. After their installation, each component will be aligned by traditional methods by means of tacheometers and optical level.

Control and maintenance of the alignment

The GANIL laboratory previously used theodolites and optical levels to set up a floor network, align magnets and carry out the final survey. Recently, we have upgraded the alignment techniques with a portable 3D measuring arm and a new motorized tacheometer. We also bought at the CERN Large Scale Metrology Group a LEICA laser tracker.

Not as surveying with a theodolite, the use of a laser tracker for the maintenance of the alignment will avoid dismantling equipment such as vacuum pumps or beam diagnostic devices during the shutdown period to permit alignment (Fig. 5).

The coordinates of fiducials of all the magnets and diagnostics boxes will be exported into a data base.

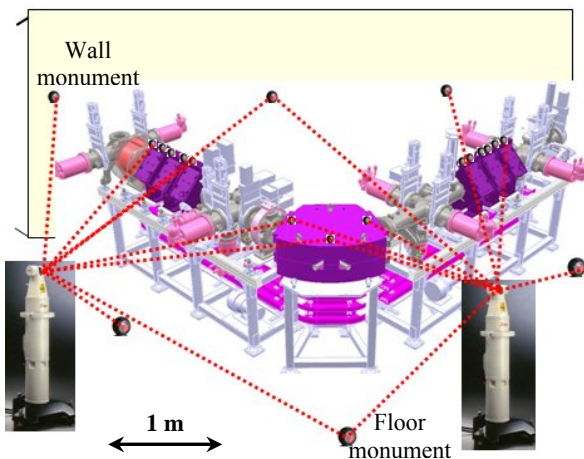

Figure 5: Alignment maintenance scheme of the injector beam line components

SURVEY AND ALIGNMENT CONCEPT OF THE RADIOFREQUENCY QUADRUPOLE (RFQ)

The SPIRAL2 Radiofrequency Quadrupole (RFQ) is designed to accelerate either a 5 mA deuteron beam ($Q/A=1/2$) or a 1mA $Q/A = 1/3$ ion beam up to 0.75 MeV/A at 88 MHz (Fig. 6). The 4 long vanes of this cavity are used to confine the particles close to the central axis. The electric fields created also have a longitudinal component due to the wave-like shape of the poles, which accelerates the particles. Located just after the ion source, the RFQ is the first step in the acceleration of the intense beams from SPIRAL2.

RFQ alignment tolerances

- Perpendicular tilt by segment: $\pm 0.1\text{mm}$
- Parallel tilt by segment: $\pm 0.1\text{mm}$
- Parallel displacement by segment : $\pm 0.1\text{mm}$
- Maximal static errors for the global alignment: $\pm 0.1\text{mm}$

RFQ fiducialization

The localization of the RFQ requires fiducial points transferred on the top of the vacuum vessel by adjustable plates equipped with a conical centering surface for a

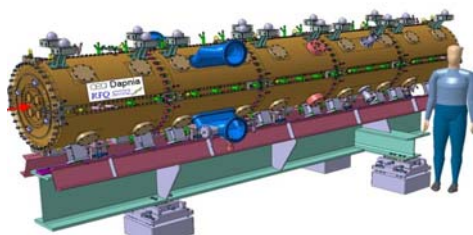

Figure 6: Mechanical design of the RFQ 3-D view CEA/DSM/DAPNIA (Saclay)

Taylor-Hobson-Sphere or retro-reflector. The centre of this sphere defines the three-dimensional measurement

point. These plates are the only reference points which will be accessible. The spatial coordinates of these plates will be given in the reference system of the object.

Metrological control of the vanes on delivery

The metrological control of the vanes position on delivery will be carried out by using a laser tracker. Four machined holes distributed out at both ends of the vacuum vessel will be used like reference system of the object (Fig.7). The measurement uncertainty is estimated to be $\pm 20\mu\text{m}$ at 2σ . It will be essential to carry out the measurement inside an air-conditioned room to get the required precision. In order to have methodology validated, it will be necessary to carry out an identical size plate to the RFQ tube diameter including fiducials. These fiducials have to reproduce the same geometric figure. The material will be chosen with a low dilatation coefficient. The distances between fiducials will have to be measured by a laboratory tests so as to have at one's disposal a standard of length.

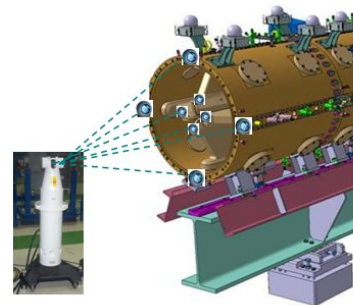

Figure 7: Vanes metrological control on delivery

Network measurement for the metrological control of the fiducial points

Network measurement will be made with a laser tracker and an optical level (Fig.8). The reference network will consist of approximately 6 pillars (green), 6 floor monuments (blue) and 4 laser tracker stations. The volume of the network is $4\text{m}\times 3.5\text{m}\times 2\text{m}$. Two sets of

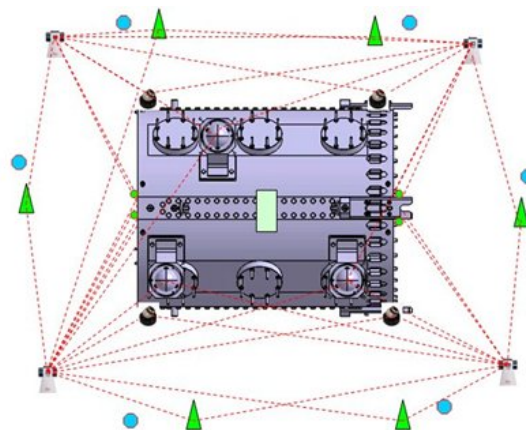

Figure 8: Network measurement scheme for metrological control of the fiducial points

angles and 8 interferometer distances will be observed from each tracker station to all points. The global error is estimated to be 60 μm (RMS at 2σ) [2]

SURVEY AND ALIGNMENT OF THE SUPERCONDUCTING LINAC

The superconducting Linac is composed of two cryomodule families, one of low beta, called Cryomodule A, and one of high beta, called Cryomodule B. According to the beam dynamics calculations, all the cavities will operate at 88 MHz: one family at $\beta = 0.07$ and the other at $\beta = 0.12$ (Fig.9).

In the framework of the project, the 'Cryomodule A' refers to the first family. Twelve superconducting cavities of this first kind take over the beam after the RFQ to continue the acceleration. In the framework of the project, the 'Cryomodule B' refers to the second family. Eighteen superconducting cavities of this type will be used along the last part of the LINAC, so that the ions reach higher velocities [3].

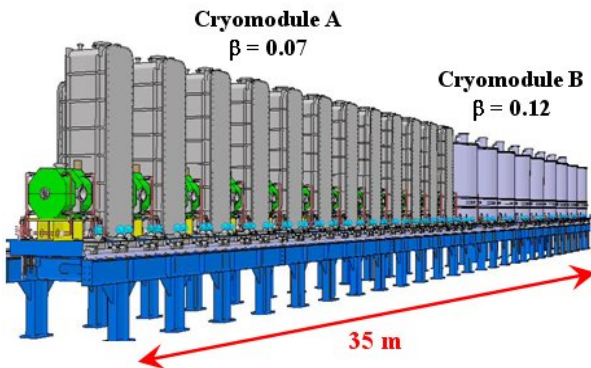

Figure 9: View of the superconducting linac

Alignment tolerances

The tolerated maximum static errors for the global alignment are:

- ± 0.1 mm for the displacement of the quadrupoles
- $\pm 0.03^\circ$ for the rotations (X,Y) of the quadrupoles
- $\pm 0.2^\circ$ for the rotation (Z) of the quadrupoles
- ± 1 mm for the displacement of the cryomodules
- $\pm 0.3^\circ$ for the rotation (X,Y) of the cryomodules
- ± 0.25 mm for the displacement of the BPM

Fiducialization of the components

The solution adopted to support the linac components is a welded-frame structure equipped with a guide rail (Fig.10). One advantage of this solution is the possibility to bring a component a laboratory together with its support in order to do, for example, a realignment of the cavities in the cryostat, then to install it back on the beam line under the same conditions, using the guide rail.

As the components cannot be aligned through the beam tube, the solution adopted is to transfer new axis outside

the object (quadrupole and cryomodule), i.e. to the sides of their supports by adjustable target boxes or fiducials (Fig. 10). These external references will allow the alignment of one cryomodule cavity with respect to the other ones. The shifting of the beam axis will be carried out on a dedicated bench.

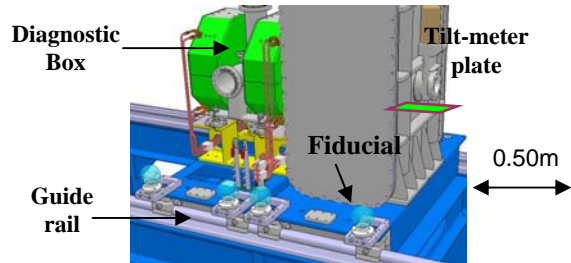

Figure 10: Cryomodule A and quadrupoles fiducialization

The alignment of the beam diagnostics in relation to the quadrupoles presupposes that the two quadrupoles will be aligned previously and will be made interdependent of the support [4].

Transfer methodology of cavities beam axis

During the assembly process, once the cryomodule is closed, the interior of the superconducting cavities cannot be accessed outside a clean room. As a result, the cavity will have to be equipped with external references (optical targets) mounted on an arm in order to facilitate its adjustment inside the cryostat (Fig.11 – cryomodules B).

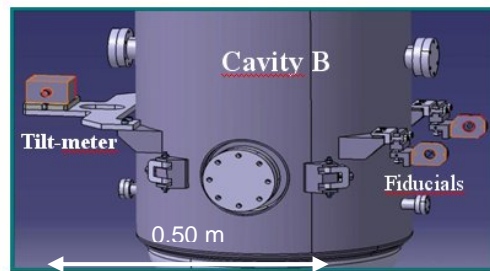

Figure 11: Target arm fixtures for transferring beam axis of the cavity B

Linac Alignment Techniques

Presently, three techniques are discussed to align the straightness of the linac:

- using laser alignment or the micro-Alignment Telescope (MAT) with CCD camera. They give both horizontal and vertical deviations simultaneously
- using a tacheometer combined with a digital level
- using a laser tracker

A test-bench has been designed (Fig. 12) to evaluate the performances of the alignment laser and the Micro-Alignment Telescope (MAT) with its CCD camera. It has been used to adapt the procedures for the measurements

and to validate the methods which will be used for the alignment of the linac components. Today, due to a lack of availability from suppliers, the MAT has not yet been tested.

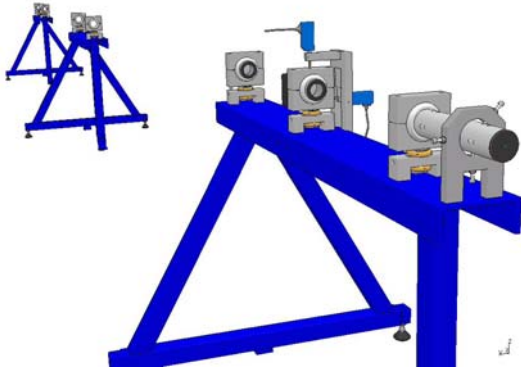

Figure 12: Test-bench design



Figure 13: Laser alignment under test

being restricted to a single approach. We must also remain very adaptable to the conditions on site.

It is also essential that the person in charge of the alignment must be involved very early in the design of the elements, in terms of fiducialization, mechanical assembly and controls.

For quality, to put the emphasis on the access to the information to all actors is very important. All documents must be stored in the same database. The use of this system of management saves a considerable amount of time making easier the organization, follow-up work and distribution of information.

ACKNOWLEDGEMENT

I would like to acknowledge all members of the GANIL design offices, as well as the colleagues from the other laboratories involved in this project, particularly from IPN ORSAY and the DAPNIA Saclay.

REFERENCES

- [1] A. Mosnier, The SPIRAL2 Project, APD Report, Survey System, Chapter VII-17 to VII-20, EDMS n°004609, January 2005
- [2] R. Beunard, SPIRAL2 Accelerator-Survey and Alignment Concept, Poster, SPIRAL2 2 Week, Nov. 2007
- [3] R. Beunard, The alignment strategy for the SPIRAL2 superconducting cryomodules, Proceedings of the 10th International Workshop on Accelerator Alignment, KEK, 2008
- [4] R. Beunard, Positioning of the Linac quadrupoles - alignment errors, internal note, EDMS n° 003379, April 2004

QUALITY ASPECT TO THE INFORMATION ACCESS

From the quality point of view, the project management puts the emphasis on the information access for all actors. All documents and files are managed using an Electronic Data Management Systems (EDMS). The documents are submitted for approval to the concerned people. Among others, for example, critical information can be shared with authorised users. The status of the documents informs on the validity of the file. The different document status are in work, released, engineering check, or cancelled.

CONCLUSION

The introduction of new technologies in our laboratories is necessary and allows significant improvements in metrology and thus in the physics experiments themselves. We consider ourselves under an obligation to put forward a variety of methods rather than