



HAL
open science

CLIC Main Beam Quadrupole, Eigen mode computation

G. Deeglise

► **To cite this version:**

| G. Deeglise. CLIC Main Beam Quadrupole, Eigen mode computation. 2010, pp.19. in2p3-00480244

HAL Id: in2p3-00480244

<https://hal.in2p3.fr/in2p3-00480244>

Submitted on 3 May 2010

HAL is a multi-disciplinary open access archive for the deposit and dissemination of scientific research documents, whether they are published or not. The documents may come from teaching and research institutions in France or abroad, or from public or private research centers.

L'archive ouverte pluridisciplinaire **HAL**, est destinée au dépôt et à la diffusion de documents scientifiques de niveau recherche, publiés ou non, émanant des établissements d'enseignement et de recherche français ou étrangers, des laboratoires publics ou privés.



Laboratoire d'Annecy-le-Vieux
de Physique des Particules

LAPP-TECH-2010-02

April 29, 2010

CLIC Main Beam Quadrupole Eigen mode computation

G. Deeglise

LAPP - Université de Savoie - CNRS/IN2P3
BP. 110, F-74941 Annecy-le-Vieux Cedex, France



In2p3





1. Introduction.....	3
2. Summary of calculations performed on previous pole shape	3
2.1 Static analysis	3
2.2 Eigen mode analysis	6
3. Eigen mode computation on final Type 4 yoke : free modal analysis	9
3.1 Considered geometry	9
3.1 Single pole, free modal analysis:	10
3.2 Full yoke free modal analysis :	12
3.3 Modeling of quadrants assembly	12
3.4 Comments on presented results	17
3.4.1 Comparison between “fully welded” and previous calculations	17
3.4.2 Comparison between « fully welded » and « locally welded »	17
3.4.3 Remarks on the “punctually welded” calculation	18
3.5 Final update on Eigen frequency calculations.....	18
4 Conclusion	19



1. Introduction

In this report, we summarise the work done on the CLIC Main Beam Quadrupole. There are about 4000 MB quadrupoles of 4 types with lengths ranging from 420mm to 1900mm. In order to obtain the desired CLIC luminosity, the MB quadrupoles have to be stable to 1nm above 1Hz. The region of interest for the study is between 0.5Hz and about 100Hz. In order to achieve the specifications, the magnet should not have any resonance peaks in this region of Interest. In addition, the magnet on its support shouldn't have any resonance peak in the same frequency range. The first step is to determine if the designed magnet has its first resonance peak above 100Hz. We are studying the longest quadrupole more susceptible to internal resonances. In a second step, the magnet on ideal supporting points has been evaluated. The current magnet design can be seen on following figure. One can see that it is composed of 4 quadrants assembled so as to have a quadrupole magnetic field. As a last step, the mechanical model has been used to study the influence of the quadrant assembly.

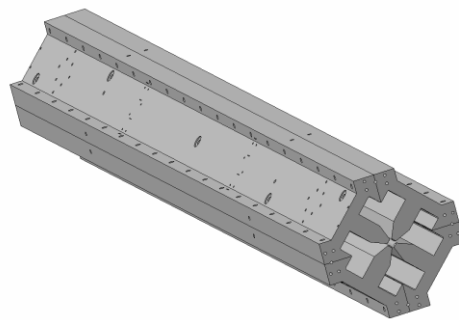

Note that in this report, the quadrant design varies slightly from one calculation to another since these studies have been performed in parallel with the magnet design process. It can be noticed that the results of the calculations are not significantly influenced by these design variations. In the last paragraph, the latest design has been considered to build finite element model.

2. Summary of calculations performed on previous pole shape

2.1 Static analysis

The aim of this calculation was to determine an order of magnitude of the static deflection under gravity acceleration. In this study, the section of the yoke has been considered monolithic, resulting from a perfect welding of the four poles. Depending on the number of supporting points, their position, these calculations lead to a vertical deflection which varies from 1 to several microns. Figures presented hereafter illustrate the deflection of the yoke considering that it is handled by two supports next to the Gauss points of the structure. These particular stations are well known to minimize the sag of a beam supported in two points.

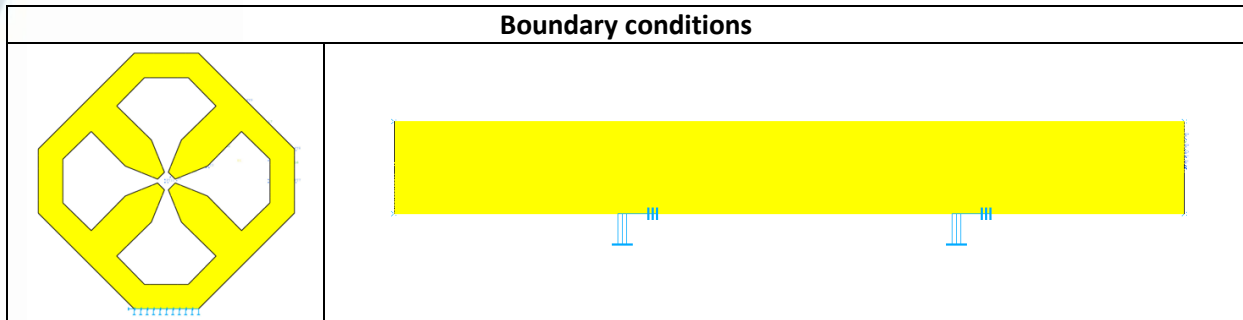

Standard steel Properties

$E = 210\,000\text{ Mpa}$

$\nu = 0.33$

$$\rho = 9.2432 \cdot E^{-9} T \cdot \text{mm}^{-3}$$

Remark : this density as been evaluated to take into account the coils masses. It has been done by considering linear masses from following array, a 1800 mm long yoke, and the finite element model total volume.

CLIC Quadrupole mass calculation (Iron and Conductor without insulation)

Material	Density [kg/m ³]	Conductor mass per meter [kg/m]	N turns per pole	From both pole sides	Number of poles	Total mass per meter [kg/m]
Copper	8.96E+03	0.183	x17	x2	x4	24.9

Material	Density [kg/m ³]	Mass 1 quadrant per meter [kg/m]	N quadrants	Total mass per meter [kg/m]
Steel 1010	7.87E+03	36.3	x4	145.2

Numerical application with :

- L = 1800 mm (considered length)

- V=3.312489e+07 mm³ (volume measured from FEM)

$$\rho = \frac{(145.2 + 24.9) \times 1800 \times 1 \cdot E^{-6}}{3.312489 \times 1 \cdot E^7} \approx 9.2432 \cdot E^{-9} T \cdot \text{mm}^{-3}$$

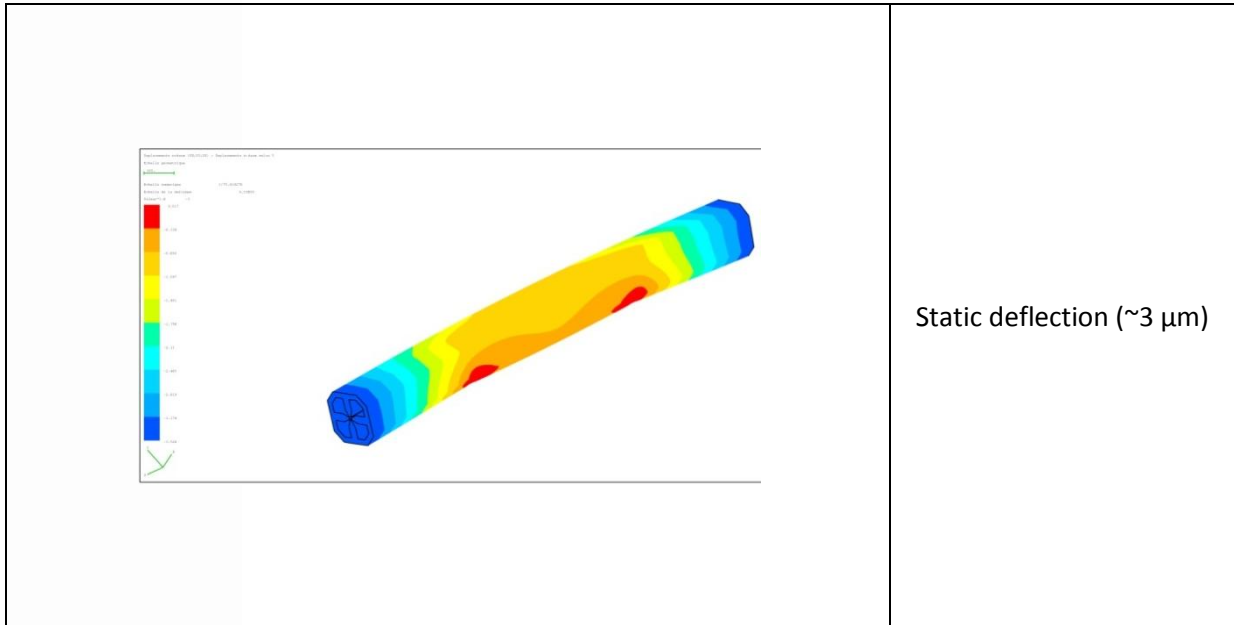

One should consider these results with parsimony, indeed, they could be quite dependent on the poles assembly method, on the position of the supporting points and on the design of the supporting system. Nevertheless, these calculations give an order of magnitude of what will be the static deflection of the yoke due to its own weight.

2.2 Eigen mode analysis

Considering the same model as described in previous paragraph, dynamic calculations have also been performed. They lead to a first free-free resonance frequency in the range of 250 Hz. The figure here after illustrates modal deformed shapes for first and third Eigen modes. The second one is not presented here since it has the same deformed shape and frequencies as the first mode. This is due to the orthogonality property of the modal basis.

Free modal analysis (no boundary conditions)	
 <p>257 Hz</p>	<p>First (and second) Eigen mode</p>
 <p>662 Hz</p>	<p>Third Eigen mode</p>

In order to have a rough estimate of what will be the dynamic behavior of the yoke taking into account the effect of boundary conditions, a second modal analysis has been performed. Considered boundary conditions are the same as for the static analysis presented previously: a clamping at Gauss point as shown on following figures. That means that the three degrees of freedom of each of the corresponding nodes are fixed.



Boundary conditions	

Associated Eigen modes	
<p>Mode 1</p>	
<p>Mode 2</p>	
<p>Mode 3 & 4</p>	
<p>Mode 5</p>	

The main difference with previous results is the appearance of a first mode at 127Hz which is almost a rotational rigid body mode. As one can see on previous figures, the frequency of the first bending mode of the yoke is slightly modified if compared to the free modal analysis. The frequency of such Eigen modes is critically dependant on boundary condition. In order to enhance this point a third

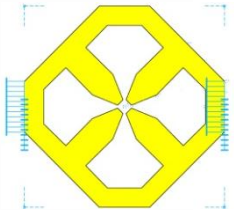

modal analysis with another supporting hypothesis has been performed and is illustrated in following figures. The boundary conditions are still applied at gauss point but on the left and right side of the magnet (instead of the lower side).

Boundary conditions	
	

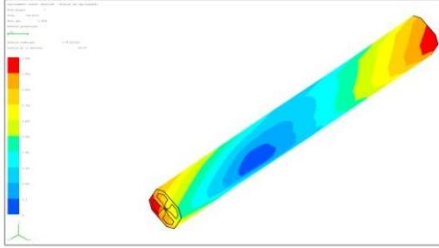
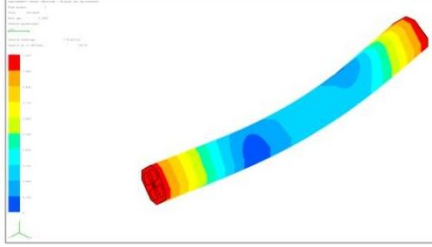
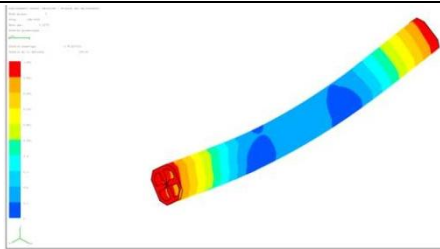
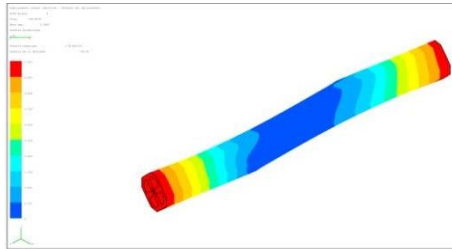
Associated Eigen modes	
Mode 1	 108 Hz
Mode 2	 231 Hz
Mode 3	 242 Hz
Mode 4	 304 Hz

To conclude, one could say that the dynamic behavior can be quite dependent on considered boundary conditions. One could say that these hyper static boundary conditions are stiffening the structure thus modifying the computed Eigen modes. Therefore, further modal analysis should be performed taking into account a more realistic supporting system in order to quantify as precisely as possible the influence of the mounting parts on the dynamic behavior. As this supporting system is still being studied, this analysis is not given in this report.

3. Eigen mode computation on final Type 4 yoke : free modal analysis

As it has been said in introduction, until the design was finalized, the shape of the poles has evolved. The aim of this paragraph is to present an update of previously presented modal calculations considering the latest shape evolutions and to present assembly studies. As it has been shown in previous paragraphs, the Eigen frequencies are influenced by the considered set of boundary conditions. Currently, the supporting system is not yet fully defined and could not be taken into account in these calculation. Consequently, the calculations presented here do not include any boundary conditions : they are free modal analysis.

3.1 Considered geometry

The considered pole shape, is the one furnished by CERN (25 September 2009). This geometry has been idealized in order to obtain a good quality mesh with a limited number of elements. These minor shape modifications consist in removing some holes and chamfers as it is illustrated on following pictures.

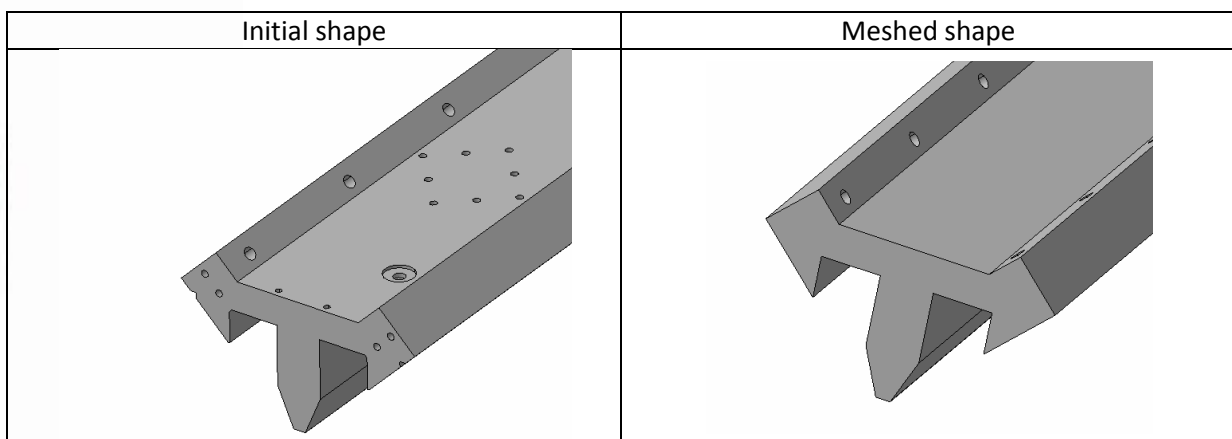



Moreover the finite element mesh does not explicitly consider the holes. Nevertheless, their position is kept by imposing a line of node to stand for their axis. This particular point is shown on following picture.

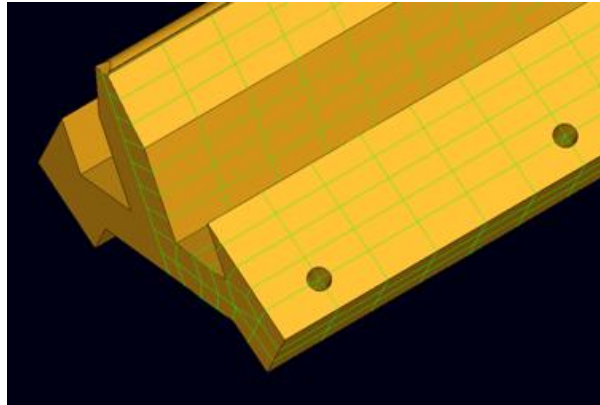

3.1 Single pole, free modal analysis:

In a first step a free modal analysis has been performed on a single pole. This calculation will be useful to compare the computed eigen frequencies with the one which will be determined experimentally. In this calculation the material is considered to be a standard steel, having the following properties :

Young modulus : $E=210000$ Mpa

Poisson ratio : $\nu = 0.3$

Density : $\rho = 7.9e-9$ T.mm⁻³

The first computed Eigen frequencies are summarized in the following table :

Mode number	Frequency (Hz)
1	114
2	212
3	278
4	306
5	551
6	563

One can refer to next page figures to have an illustration of the corresponding modal deformed shapes.

Single pole free modal analysis : deformed shapes	
<p>First Eigen mode</p> <p>Bending mode</p> <p>F = 114 Hz</p>	<p>Analyse modale libre libre un pole seul</p> <p>Déplacements nodaux (00,00,00) : Modèles des déplacements</p> <p>Mode groupe 1</p> <p>Freq. : 113.7083</p> <p>Mass. spec. : 0.0012</p> <p>Échelle géométrique : 1.0000</p> <p>Échelle nodologique : 1/50.00000</p> <p>Échelle de la déformation : 100.00</p>
<p>Second Eigen mode</p> <p>Bending mode(slightly coupled with torsion)</p> <p>F = 212 Hz</p>	<p>SAMCEF</p> <p>Analyse modale libre libre un pole seul</p> <p>Déplacements nodaux (00,00,00) : Modèles des déplacements</p> <p>Mode groupe 2</p> <p>Freq. : 211</p> <p>Mass. spec. : 0.0012</p> <p>Échelle géométrique : 1.0000</p> <p>Échelle nodologique : 1.0000000</p> <p>Échelle de la déformation : 100.00</p>
<p>Third Eigen mode</p> <p>Torsion mode</p> <p>F = 278 Hz</p>	<p>SAMCEF</p> <p>Analyse modale libre libre un pole seul</p> <p>Déplacements nodaux (00,00,00) : Modèles des déplacements</p> <p>Mode groupe 3</p> <p>Freq. : 278.0000</p> <p>Mass. spec. : 0.0010</p> <p>Échelle géométrique : 1.0000</p> <p>Échelle nodologique : 1/70.00000</p> <p>Échelle de la déformation : 100.00</p>
<p>Fourth Eigen mode</p> <p>Bending mode</p> <p>F = 306 Hz</p>	<p>SAMCEF</p> <p>Analyse modale libre libre un pole seul</p> <p>Déplacements nodaux (00,00,00) : Modèles des déplacements</p> <p>Mode groupe 4</p> <p>Freq. : 306.0000</p> <p>Mass. spec. : 0.0010</p> <p>Échelle géométrique : 1.0000</p> <p>Échelle nodologique : 1/70.00000</p> <p>Échelle de la déformation : 100.00</p>



3.2 Full yoke free modal analysis :

3.2.1 Physical properties

The considered material for this simulation is the same standard steel as in previous paragraph except for its density. This value has been evaluated to take into account the coils masses. It has been done by considering linear masses from following array , a 1844 mm long yoke, and the finite element model total volume. It leads to a 313.6 Kg yoke. This calculation is based on the same reasoning as in paragraph 2.1 but adapting the total weight of the yoke to the new finite element model volume.

Young modulus : $E=210000$ Mpa

Poisson ratio : $\nu = 0.3$

Density : $\rho = 7.38407e-9$ T.mm⁻³

CLIC Quadrupole mass calculation (Iron and Conductor without insulation)

Material	Density [kg/m ³]	Conductor mass per meter [kg/m]	N turns per pole	From both pole sides	Number of poles	Total mass per meter [kg/m]
Copper	8.96E+03	0.183	x17	x2	x4	24.9

Material	Density [kg/m ³]	Mass 1 quadrant per meter [kg/m]	N quadrants	Total mass per meter [kg/m]
Steel 1010	7.87E+03	36.3	x4	145.2

3.3 Modeling of quadrants assembly

In the next section results will be presented for three different modeling approaches of the quadrants assembly. In the first one it is considered that quadrants are fully welded together (no more consideration of bolt locations). In the second one, poles are connected locally through nodes located on a given area around bolts location. This calculation will be named "Locally welded". In the third and last one, named "Punctually welded" the influence radius of bolt has been lowered down to the minimal value that can be achieved with this mesh.

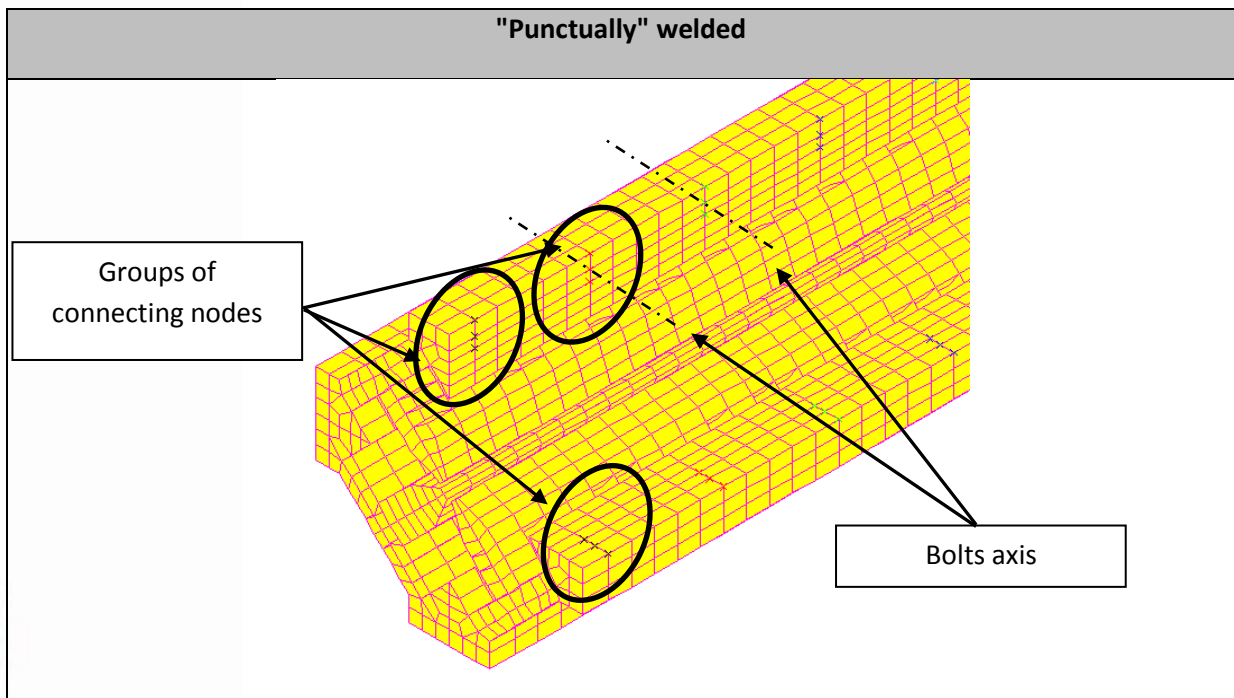
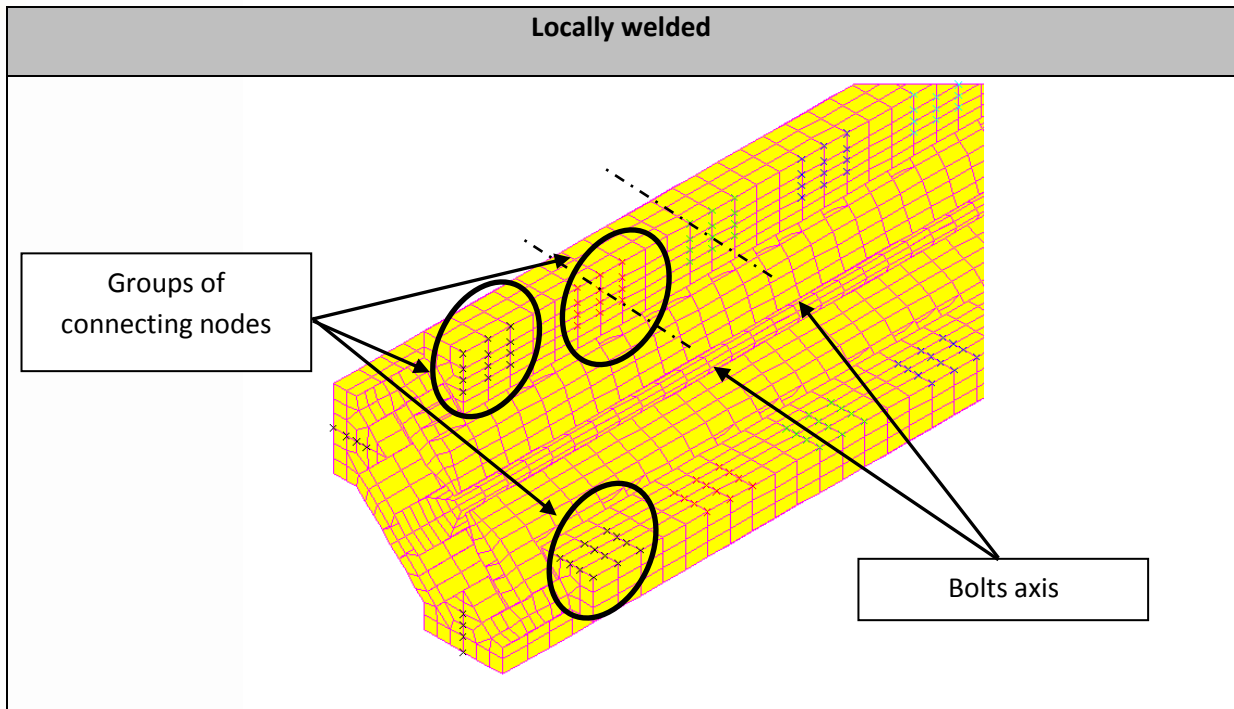

In next pages results of these three different modal calculations will be presented. These results are discussed afterwards.

Fully welded yoke	
<p>First and second Eigen modes</p> <p>Bending mode</p> <p>F = 307 Hz</p>	<p>Deplacements nodaux (DX,DY,DZ) : Modules des deplacements</p> <p>Mode propre 1</p> <p>Freq. 307.8161</p> <p>Mass gen. 0.0894</p> <p>Echelle geometrique</p> <p>100.</p> <p>Echelle numerique 1/71.885063</p> <p>Echelle de la deformee 184.40</p>
<p>Third and fourth Eigen modes</p> <p>Bending mode</p> <p>F = 746 Hz</p>	<p>Deplacements nodaux (DX,DY,DZ) : Modules des deplacements</p> <p>Mode propre 3</p> <p>Freq. 746.7548</p> <p>Mass gen. 0.1028</p> <p>Echelle geometrique</p> <p>100.</p> <p>Echelle numerique 1/71.885063</p> <p>Echelle de la deformee 184.40</p>
<p>Fifth Eigen mode</p> <p>Torsion mode</p> <p>F = 755 Hz</p>	<p>Deplacements nodaux (DX,DY,DZ) : Modules des deplacements</p> <p>Mode propre 5</p> <p>Freq. 755.0659</p> <p>Mass gen. 0.0815</p> <p>Echelle geometrique</p> <p>100.</p> <p>Echelle numerique 1/71.885063</p> <p>Echelle de la deformee 184.40</p>
<p>Sixth Eigen mode</p> <p>Section breathing mode</p> <p>F=1336 Hz</p>	<p>Deplacements nodaux (DX,DY,DZ) : Modules des deplacements</p> <p>Mode propre 6</p> <p>Freq. 1136.0859</p> <p>Mass gen. 0.1305</p> <p>Echelle geometrique</p> <p>100.</p> <p>Echelle numerique 1/16.083051</p> <p>Echelle de la deformee 30.00</p>

Locally welded yoke	
<p>First and second Eigen modes</p> <p>Bending mode</p> <p>F = 306 Hz</p>	<p>Deplacements nodaux (DX,DY,DZ) : Modules des deplacements</p> <p>Mode propre 1</p> <p>Freq. 306.3776</p> <p>Mass gen. 0.0850</p> <p>Echelle geometrique</p> <p>100.</p> <p>Echelle numerique 1/71.885063</p> <p>Echelle de la deformee 184.40</p>
<p>Third Eigen modes</p> <p>Torsion mode</p> <p>F = 723 Hz</p>	<p>Deplacements nodaux (DX,DY,DZ) : Modules des deplacements</p> <p>Mode propre 3</p> <p>Freq. 723.8419</p> <p>Mass gen. 0.0816</p> <p>Echelle geometrique</p> <p>100.</p> <p>Echelle numerique 1/71.885063</p> <p>Echelle de la deformee 184.40</p>
<p>Fourth and Fifth Eigen mode</p> <p>Bending mode</p> <p>F = 736 Hz</p>	<p>Deplacements nodaux (DX,DY,DZ) : Modules des deplacements</p> <p>Mode propre 4</p> <p>Freq. 736.7778</p> <p>Mass gen. 0.1055</p> <p>Echelle geometrique</p> <p>100.</p> <p>Echelle numerique 1/71.885063</p> <p>Echelle de la deformee 184.40</p>
<p>Sixth Eigen mode</p> <p>Section breathing mode</p> <p>F=1033Hz</p>	<p>Deplacements nodaux (DX,DY,DZ) : Modules des deplacements</p> <p>Mode propre 6</p> <p>Freq. 1033.9309</p> <p>Mass gen. 0.1483</p> <p>Echelle geometrique</p> <p>100.</p> <p>Echelle numerique 1/16.083051</p> <p>Echelle de la deformee 30.00</p>

"Punctually" welded yoke

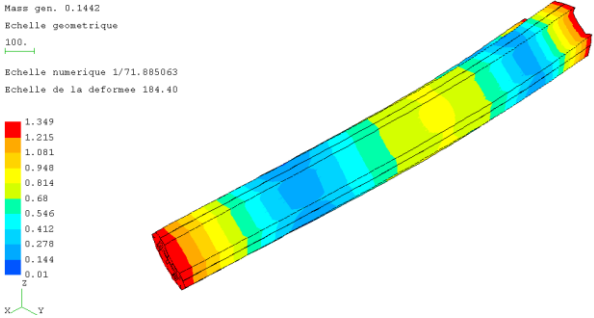
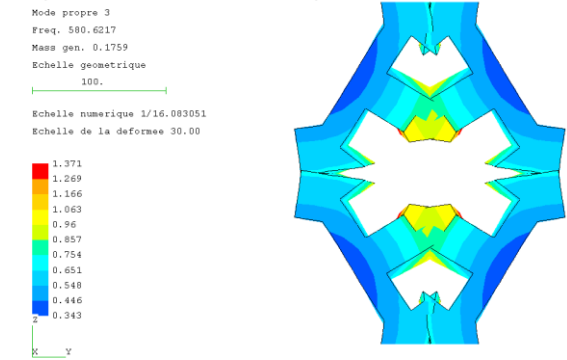
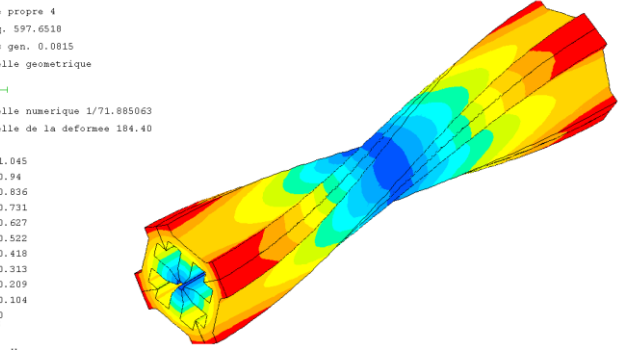
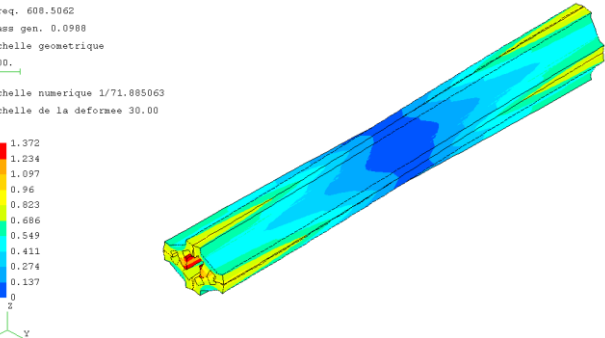
<p>First and second Eigen modes</p> <p>Bending mode</p> <p>F = 249 Hz</p>	<p>Deplacements nodaux (DX,DY,DZ) : Modules des déplacements</p> <p>Mode propre 1</p> <p>Freq. 298.5201</p> <p>Mass gen. 0.1442</p> <p>Echelle geometrique 100.</p> <p>Echelle numerique 1/71.885063</p> <p>Echelle de la deformation 184.40</p> 
<p>Third Eigen modes</p> <p>Section breathing mode</p> <p>F = 580 Hz</p>	<p>Deplacements nodaux (DX,DY,DZ) : Modules des déplacements</p> <p>Mode propre 3</p> <p>Freq. 580.6217</p> <p>Mass gen. 0.1759</p> <p>Echelle geometrique 100.</p> <p>Echelle numerique 1/16.083051</p> <p>Echelle de la deformation 30.00</p> 
<p>Fourth Eigen mode</p> <p>Torsion mode</p> <p>F = 597 Hz</p>	<p>Deplacements nodaux (DX,DY,DZ) : Modules des déplacements</p> <p>Mode propre 4</p> <p>Freq. 597.6510</p> <p>Mass gen. 0.0815</p> <p>Echelle geometrique 100.</p> <p>Echelle numerique 1/71.885063</p> <p>Echelle de la deformation 184.40</p> 
<p>Fifth Eigen mode</p> <p>Section breathing mode</p> <p>F=608 Hz</p>	<p>Deplacements nodaux (DX,DY,DZ) : Modules des déplacements</p> <p>Mode propre 5</p> <p>Freq. 608.5062</p> <p>Mass gen. 0.0988</p> <p>Echelle geometrique 100.</p> <p>Echelle numerique 1/71.885063</p> <p>Echelle de la deformation 30.00</p> 

3.4 Comments on presented results

In previous arrays, some modes have a single illustration for two modes. As it has been said before, this is due to the fact that they have the same deformed shape and frequency (mode's orthogonality property).

3.4.1 Comparison between “fully welded” and previous calculations

If compared to calculations performed on the first pole shape, results of the "Fully welded" finite element model enhance a first resonance frequency which is higher (307 Hz / 257 Hz). This difference is due to the quadrant shape evolution and especially to the material added on the outside of the quadrant (see following figure). This additional material is located far from the center of gravity of the section and thus generate an increase of the inertia of the quadrant.

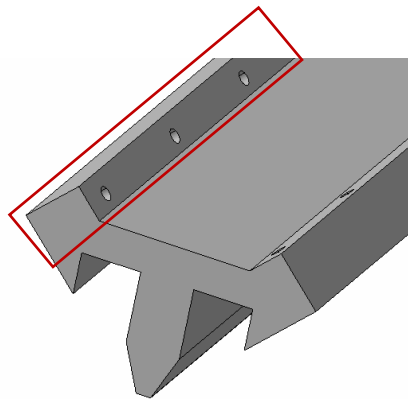

3.4.2 Comparison between « fully welded » and « locally welded »

As a main point, one can notice that results of the "Fully welded" calculation and the "Locally welded" calculation are very similar. First and second Eigen modes are unchanged but modes three and four have their order flipped. This is due to a differential sensitivity of these two modes to the welding parameter. One can deduce from this that a relatively low bolt tension would lower the twisting mode frequency more than it would lower the second bending mode frequency. The main conclusion of this comparison is the non evolution of the first Eigen frequency and the relatively low evolution of higher order modes frequencies.



3.4.3 Remarks on the “punctually welded” calculation

This calculation is presented here to complete the understanding of the influence of assembly method on yoke Eigen frequencies. This assembly modeling is quite far from reality : it does not take into account the fact that the preload of the bolt generate a region were friction between quadrants has a strong impact on the assembly strength. Nevertheless, some results of this calculation are interesting to consider. For example, the obtained frequency of the first bending mode is still above 200 Hz even when considering a weak junction between poles.

3.5 Final update on Eigen frequency calculations

The aim of this paragraph is to update the previously computed Eigen frequencies. Indeed, in these calculations the linear mass estimation of the coil was not in accordance with the final design. The last data we received about the coil mass are the following ones :

Copper linear mass (Kg / m)	Total copper length/coil (m)	Coil mass / quadrant (Kg)	Total coil mass (Kg)
0.183	66.3	12.1	48.5

Finite element volume (mm ³)	Additional density (T/mm ³)	Steel 1010 density (T/mm ³)	Density to be considered for Eigen mode computation (T/mm ³)
4.25E+07	1.14E-09	7.86E-09	9.00E-09

The following array summarize the obtained results by this new density and a "fully welded yoke". Of course, when taking into account an additional mass, the Eigen frequencies are lowered and one could notice that these changes, in a first approximation, are proportional to the square root of the density ratio.



$$\frac{F_1}{F_2} \approx \sqrt{\frac{\rho_1}{\rho_2}}$$

Updated frequency (Hz)	Previous frequency (Hz)	Ratio	Analytical foreseen ratio
279	307	1.101	1.104
676	746	1.103	1.104
684	755	1.104	1.104
1029	1336	1.298	1.104

Remark : Deformed shapes are not presented here since they are unchanged.

4 Conclusion

To conclude one should keep in mind that, for a given geometry, the Eigen frequencies of the yoke are very dependent on the way that it is supported. Because of the number of bolts, and because of their tightening, the four quadrants should be considered as well connected. Therefore the "Fully welded" hypothesis, is the most accurate one. Recent experimental measurements performed on the prototype built at LAPP have confirmed this point by demonstrating an error on frequencies which is below 5%. First calculated Eigen frequencies are in the range of 280 Hz (boundary free conditions) and it is planned to check it experimentally on a coil equipped prototype.