



**HAL**  
open science

## Beam Intensity and Energy Control for the SPIRAL2 Facility

C. Jamet, T. André, B. Ducoudret, C. Doutressoulles, W. Le Coz, G. Ledu, S. Leloir, S. Loret

► **To cite this version:**

C. Jamet, T. André, B. Ducoudret, C. Doutressoulles, W. Le Coz, et al.. Beam Intensity and Energy Control for the SPIRAL2 Facility. XXVI Linear Accelerator Conference - LINAC12, Sep 2012, Tel Aviv, Israel. pp.537-539. in2p3-00855606

**HAL Id: in2p3-00855606**

**<https://hal.in2p3.fr/in2p3-00855606>**

Submitted on 29 Aug 2013

**HAL** is a multi-disciplinary open access archive for the deposit and dissemination of scientific research documents, whether they are published or not. The documents may come from teaching and research institutions in France or abroad, or from public or private research centers.

L'archive ouverte pluridisciplinaire **HAL**, est destinée au dépôt et à la diffusion de documents scientifiques de niveau recherche, publiés ou non, émanant des établissements d'enseignement et de recherche français ou étrangers, des laboratoires publics ou privés.

## BEAM INTENSITY AND ENERGY CONTROL FOR THE SPIRAL2 FACILITY

C. Jamet, T. Andre, B. Ducoudret, C. Doutressoulles, W. Le Coz, G. Ledu, S. Leloir, S. Loret,  
GANIL, Caen, France

### Abstract

The first part of the SPIRAL2 facility, which entered last year in the construction phase at GANIL in France, consists of an ion source, a deuteron and a proton source, a RFQ and a superconducting linear accelerator delivering high intensities, up to 5 mA and 40 MeV for the deuteron beams.

Diagnostic developments have been done to control both beam intensity and energy by non-interceptive methods at the linac exit. The beam current is measured by using couples of ACCT-DCCT installed along the lines and the beam energy by using a time of flight device.

This paper gives explanations about the technical solutions, the results and resolutions for measuring and controlling the beam.

### ACCELERATOR CHARACTERISTICS

The SPIRAL2 accelerator, an extension of the GANIL laboratory is under construction at CAEN in France [1].

The beams accelerated by the Linac will range in intensity from a few 10  $\mu$ A to 1mA for ions, up to 5 mA for deuterons, and in energy from 0.75 up to 14.5 MeV/A for ions, 20 MeV/A for deuterons and 33 MeV for protons.

### BEAM CONTROLS

In order to control these beam characteristics, measuring chains and controlling devices are under development by the Electronic Machine Group at GANIL.

Controls of the beam intensity, efficiency, energy and beam power, will be necessary for the kick-off authorization issue by the French Nuclear Safety Authority (ASN).

These surveillances are part of the Machine Protection System (MPS) [2] and have to bring:

- A thermal protection, against direct beam damages, requiring a fast response time (few 10  $\mu$ s)
- An enlarged protection which controls the operation domain from the safety point of view.

### Characteristics of the Beam Intensity

Intensity range:

- Few 10  $\mu$ A to 5mA

Duty cycle of the slow chopper:

- From 1/10000 to 1/1 (frequency of 1Hz from 1/10000 to 1/2000 and a frequency of 5Hz from 1/2000 to 1/1)

Duty cycle of the fast chopper:

- From 1/1000 to 1/100 (repetition frequency from 8,88 kHz to 880 kHz)

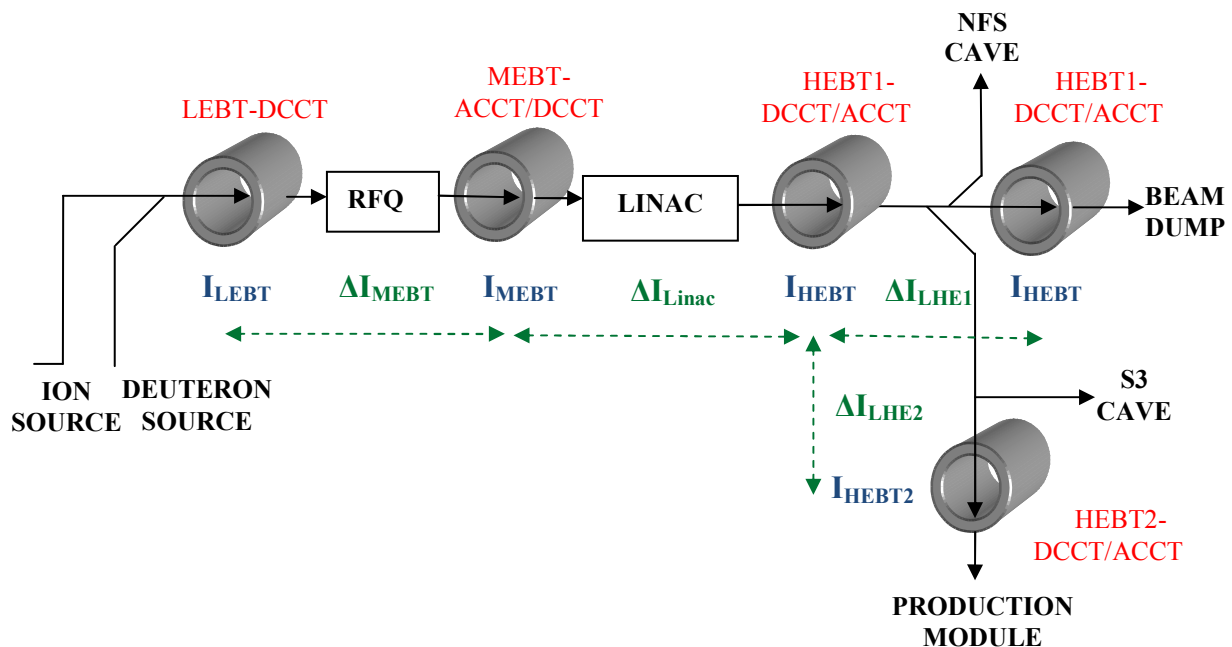

Figure 1: Scheme of the beam intensity and the beam efficiency control.

## BEAM INTENSITY DIAGNOSTICS

Two kinds of transformers are used to measure the beam intensity by a non-interceptive method, DCCT (NPCT) and ACCT. A Bergoz NPCT and a homemade ACCT inside a magnetic shield, compose an ACCT-DCCT couple.

In a first time, three ACCT-DCCT blocks are built and under qualification.

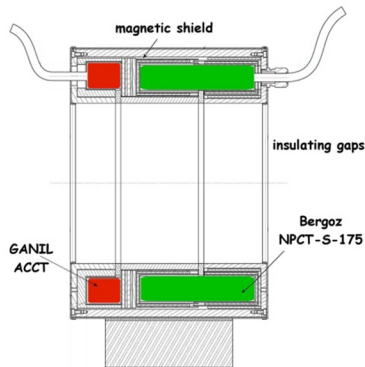

Figure 2: Design of an ACCT-DCCT couple.

### Transformer Descriptions

DCCT: NPCT-175-C030-HR

ACCT:

Torus: Nanocrystalin

Turn ratio: 300:1

Internal diameter: 184 mm

External diameter: 220 mm

ACCT and DCCT diagnostics are complementary. The DCCT, a commercial device, measures the intensity of continuous and chopped beams (response time around 50  $\mu$ s for a bandwidth of 10 kHz), the minimum intensity is around a few dozens of  $\mu$ A without offset compensation. The ACCT chain is faster with a response time less than 1  $\mu$ s (bandwidth more than 300 kHz) and an intensity accuracy better than 10  $\mu$ A but it needs a chopped beam.

### Uncertainty Evaluation

Controls are done by comparison between the beam characteristics and thresholds. Each applied threshold value has to take account of the chain accuracy, to ensure that the beam characteristic is under the intended threshold.

The ACCT-DCCT measurement chains are limited by the following parameters:

- The offset
- The thermal noise
- The electromagnetic disturbances
- The linearity and accuracy of the gain
- The temporal shift between two chains for the efficiency measurement
- The low drop for the ACCT

Each uncertainty has been evaluated and added.

For the DCCT, the main influences, which limit the accuracy, are the thermal noise and the offset due to the temperature and the magnetic field level. In order to decrease the effect of the offset, a beam periodic interruption is planned to deduct the signal without beam (offset). Few measures per hour are foreseen. The noise is limited by reducing the electronic bandwidth.

For the ACCT, the main parameters are also the electronic offset (estimation of 10  $\mu$ A) and the thermal noise (1  $\mu$ A with a bandwidth of 100 kHz). Currently, an optimization of the electronic is to decrease the offset value.

### Electronic Monitoring

In order to control quickly the beam intensity, with an important duty cycle and a slow frequency of the chopper, the electronic monitoring consists in integrating the beam intensity on a given period (fig. 3). The control is based on a beam charge threshold rather than a beam intensity threshold.

The required performances [2] are the following:

- For a 200 kW 20 MeV/A beam loss (5 mA), response time is 35  $\mu$ s
- For a 50 W 20 MeV/A beam loss (1.25  $\mu$ A), response time is 140ms

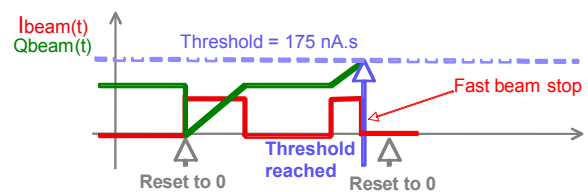

Figure 3: Principle of beam intensity integration.

## BEAM ENERGY MEASUREMENTS

Three electrodes installed along the HEBT will measure the beam energy at the exit of the LINAC by a time of flight method (TOF). The required performances are the following:

- Intensity range: from 50  $\mu$ A to 5 mA
- Energy range: from 2 MeV/A to 33 MeV/A
- Response time: 1 s
- Required accuracy:
  - +/-1 per mille for the beam tuning
  - +/-1 per cent for the beam control

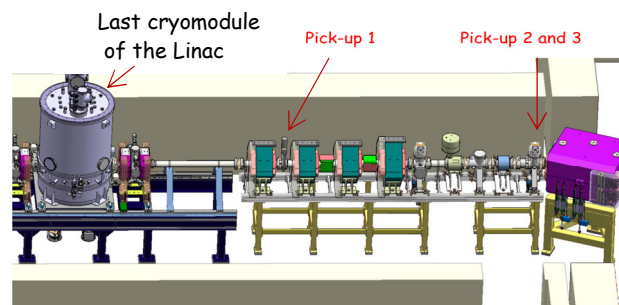

Figure 4: Electrodes along the HEBT line.

The first unit includes the Pick-up1 and the second unit is composed by the Pick-up2 and 3. The pick-up3 is designed to determine the bunch number between the two first pick-ups [3], the length between the second and the third pick-ups is calculated to be smaller than the distance between two bunches.

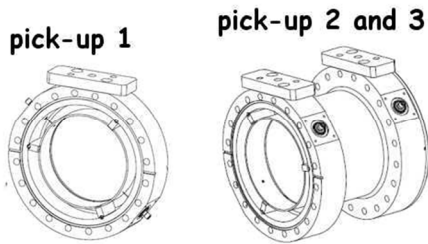

Figure 5: Design of the pick-up electrodes

*Time of Flight Values*

Table1: Lengths, Bunch Number at Min and Max Energy

Energy	Linac	
	2MeV/A	33MeV/A
$\beta$	0.066	0.2607
$L_{12}$ (mm)	3878.8	
$L_{23}$ (mm)	130	
$L_{acc}$ (mm)	224.4	886.4
N	17	4

- $L_{12}$  : Length between the pick-up 1 and 2
- $L_{23}$  : Length between the pick-up 2 and 3
- $L_{acc}$  : Length between 2 bunches
- N: Bunch number between the pick-up 1 and 2
- v: Beam velocity
- $\phi_{12}$ : Pick-up1 phase - Pick-up2 phase

$$v = \frac{L_{12}}{T_{12}} = \frac{L_{12}}{T_{acc}(N + \frac{\phi_{12}}{360})} = 360 \cdot \frac{L_{12}}{360 \cdot N + \phi_{12}} \cdot f_{acc}$$

The energy accuracy ( $\Delta E$ ) is function of the length accuracy ( $\Delta L$ ) and the phase accuracy ( $\Delta \phi$ ).

$$\left| \frac{\Delta E}{E} \right| \approx 2 \cdot \left| \frac{\Delta L_{12}}{L_{12}} \right| + 2 \cdot \left| \frac{2 \Delta \phi}{360 \cdot N + (\phi_{12})} \right|$$

*Electronic Developments*

A new electronic device has been developed at GANIL to measure the phase and amplitude of pick-up signals and calculate the beam energy. The principle consists in directly digitizing the pick-up pulses by under-sampling. The phase and amplitude of different harmonics are then calculated with a FPGA by an I/Q method before the beam energy calculation [4].

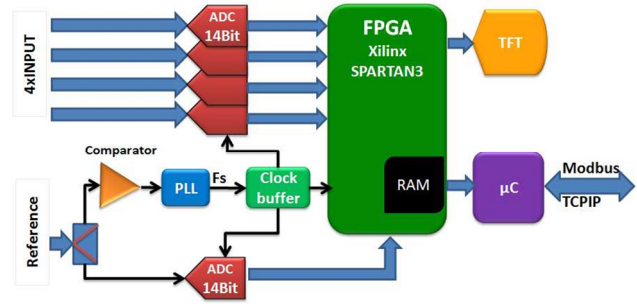

Figure 6: Synoptic of the acquisition electronic.

*Beam Tests at the GANIL's Accelerator*

Beam Tests have been done at GANIL to compare the beam energy measurements by the TOF method and the spectrometer method. The goal is to compare the values between these two methods and evaluate the TOF accuracy. The gap of the measured values is included between -1 ‰ and -3 ‰ in energy corresponding to -0.5° to -1.5° in phase (with a beam intensity from 1µA to 5 µA).

By projection of these results and by taking account of the length accuracy, calculations give an energy accuracy included between 1 to 3 per thousand in the HEBT.

**CONCLUSIONS**

Currently the ACCT-DCCT blocks are made, the ACCT electronic is under development, and an optimization to decrease the electronic offset is in progress. The next step consists in studying and in carrying out the intensity and efficiency control device. The required performances in response time and in sensitivity are very restrictive.

For the TOF device, the chain uncertainties are under evaluation in order to characterize this device. The electronics will be ready at the end of this year to measure the beam energy at the exit of the RFQ. For the HEBT, an evolution of this electronic is scheduled to make the device safer and to fulfil the safety requirements.

**REFERENCES**

- [1] P. Bertrand et al., "SPIRAL2 accelerator construction progress", this conference.
- [2] M. Moscatello et al., Machine Protection System for the SPIRAL2 Facility, IPAC2012, New Orleans, Louisiana, USA.
- [3] C. Jamet et al., Spiral2 Beam Energy Measurement, DIPAC11, Hamburg, Germany.
- [4] C. Jamet et al., Phase and amplitude measurement for the SPIRAL2 Accelerator, DIPAC09, Basel, Switzerland.