



HAL
open science

Measurement and Control of the Beam Energy for the SPIRAL2 Accelerator

W. Le Coz, C. Doutressoulles, C. Jamet, G. Ledu, S. Loret, C. Potier de
Courcy

► **To cite this version:**

W. Le Coz, C. Doutressoulles, C. Jamet, G. Ledu, S. Loret, et al.. Measurement and Control of the Beam Energy for the SPIRAL2 Accelerator. 2nd International Beam Instrumentation Conference - IBIC2013, Sep 2013, Oxford, United Kingdom. pp.897-899, 2013. in2p3-00862375

HAL Id: in2p3-00862375

<https://hal.in2p3.fr/in2p3-00862375>

Submitted on 11 Mar 2014

HAL is a multi-disciplinary open access archive for the deposit and dissemination of scientific research documents, whether they are published or not. The documents may come from teaching and research institutions in France or abroad, or from public or private research centers.

L'archive ouverte pluridisciplinaire **HAL**, est destinée au dépôt et à la diffusion de documents scientifiques de niveau recherche, publiés ou non, émanant des établissements d'enseignement et de recherche français ou étrangers, des laboratoires publics ou privés.

MEASUREMENT AND CONTROL OF THE BEAM ENERGY FOR THE SPIRAL2 ACCELERATOR

W. Le Coz[#], C. Doutressoulles, C. Jamet, G. Ledu, S. Loret, C. Potier de Courcy
GANIL, Caen, France

Abstract

The first part of the SPIRAL2 facility, which entered in the construction phase at GANIL in France, will be composed of an ion source, a deuteron/proton source, an RFQ and a superconducting linear accelerator delivering high intensities, up to 5mA and 40MeV for the deuteron beams. As part of the MEBT commissioning, the beam energy will be measured on the BTI (Bench of Intermediate Test) at the exit of the RFQ. At the exit of the LINAC, the system has to measure but also to control the beam energy. The control consists in ensuring that the beam energy is under a limit by taking account of the measurement uncertainty. The energy is measured by a method of time of flight; the signal is captured by non-intercepting capacitive pick-ups. This paper presents also the results obtained in terms of uncertainties and dynamics of measures.

INTRODUCTION

The beam energy at the exit of the LINAC will be measured for the beam tuning but also for the energy control. The energy is monitored in order to ensure the respect of the accelerator operating range and the protection of the machine (MPS). The energy is measured by a method of time of flight (TOF) [1].

As the energy control is part of the safety functions, Failure Modes and Effects Analysis (FMEA) and the measurement uncertainty are required on this control device.

ELECTRONIC DESCRIPTION

The phase measurement of the TOF is based on an electronic system which realizes the lock-in amplifier function [2]. The pulse signals come from 3 pick-up electrodes. The phase of first harmonic is measured by the TOF device.

The TOF electronic system is composed by:

- ADCs card with a clock part
- FPGA card
- Microcontroller card
- High Frequency Amplifier
- Alarm card

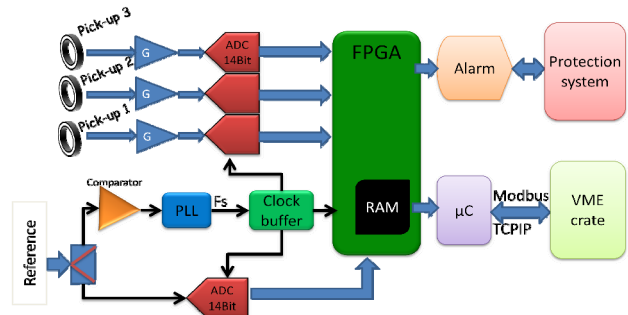

Figure 1: Electronic synoptic.

TEST BENCH IN LABORATORY

Phase coherence, which is a stable phase relationship between signals, is essential when measurements require more than one RF output. The inherent phase instability among multiple signal generators is mostly overcome by using a common signal/LO source for each generator [4].

The function generator Tektronix offers two tightly synchronized outputs. The phases of each channel can be independently adjusted.

The first output is used as the reference signal of the TOF system. The reference frequency is 88MHz at a fixed level.

The second signal is used to simulate the first harmonic from a diagnostic and is connected to the inputs of the TOF system, via a splitter. To adjust levels in a large dynamic, various attenuators are located before the splitter.

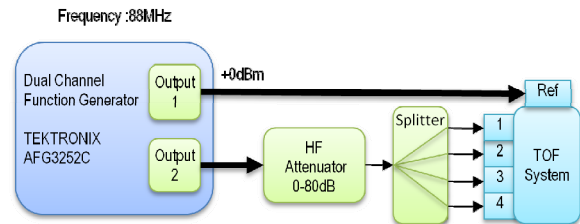

Figure 2: Measurement chain.

VELOCITY AND ENERGY UNCERTAINTY

Velocity Calculation

The level of the energy threshold has to take into account the measurement uncertainty.

Threshold level = Required threshold-uncertainty

ISBN 978-3-95450-127-4

[#]lecoz@ganil.fr

The Time of Flight Method consists in measuring the time difference between signals produced by bunches on two pick-ups. The time can be calculated from the pick-up phase. As the length between pick-ups is known, the velocity is obtained (see Eq. 1) [3].

However the number of bunches included between the first two pick-ups has to be taken into account.

The third pick-up is thus used to determine this number N of bunches.

$$v = \frac{L_{12}}{T_{12}} = \frac{L_{12}}{T_{acc}(N + \frac{\phi_{12}}{360})} = 360 \cdot \frac{L_{12}}{360N + \phi_{12}} \cdot F_{acc} \quad (1)$$

L_{12} : Length between the pick-up 1 and 2

F_{acc} : Accelerator Frequency

N: Bunch number between the pick-up 1 and 2

v: Beam velocity

ϕ_{12} : Pick-up1 phase - Pick-up2 phase

Uncertainty Formulas

The standard measurement uncertainty of velocity (see Eq. 2) is related to the distance between electrodes and the signal phase of pick-up.

$$\frac{u_E}{E} = 2 \cdot \frac{u_V}{V}, \quad \frac{u_v}{v} = \left(\frac{u_l}{l} + \frac{u_{\phi_1} - u_{\phi_2}}{360N + (\phi_1 - \phi_2)} \right) \quad (2)$$

U_E : Energy uncertainty

U_V : Velocity uncertainty

U_L : Length uncertainty

U_ϕ : phase uncertainty

Uncertainty of the Length Between Probes

The distance between the first two probes is 3878.8 mm in the HEBT. The distance uncertainty is the sum of uncertainties on:

- The measuring device
- The position of the fiducials
- The manufacturing of the fiducial position
- The dilation of the material due to the temperature variations

Uncertainty of the Phase Linearity

At constant level, the measuring bench sets from 0 to 360° the phase of the channel 2 of the generator compared with the reference phase. This method allows to measure the linearity of the phase.

Uncertainty of Delay Correction

Cables between probes and electronics insert a delay. Before making a measure of phase, a delay deduction of each chain must be done. This delay correction is

measured between the phase of each chain and the reference signal. The uncertainty of the delay correction is thus the sum of the uncertainties determined above the level of 0dBm.

Uncertainty of Temperature

Under normal conditions, the temperature in the accelerator rooms is evaluated between 15°C to 31°C.

ENERGY UNCERTAINTY

The next datasheet (Table 1) resumes the uncertainties for different input levels.

Table 1: Statement of the Phase Components Uncertainties

Source of uncertainty	0dBm (delay)	-60dBm	-80dBm
phase noise	0.03°	0.04°	0.21°
linearity	0.08°	0.7°	3.5°
temperature	0.016°C	0.016°C	0.016°C
distance	0.48mm	0.48mm	0.48mm

The figure 3 shows the expanded uncertainty of energy depending of the signal level and the beam energy.

The energy uncertainty increases when the signal level decreases and when the velocity increases.

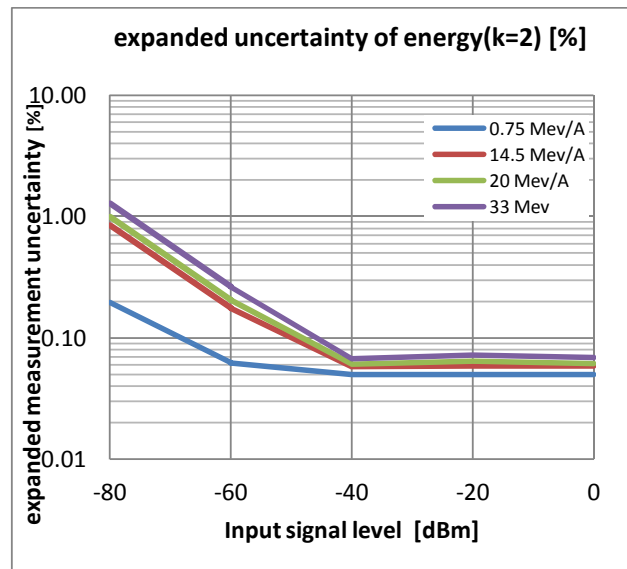

Figure 3: Expanded uncertainty of energy.

For a level under -40dBm, the uncertainty increase is due to the augmentation of nonlinearity and decrease of the signal to noise ratio.

MONTE-CARLO ANALYSIS

A Monte-Carlo method, adopted in the Guide to the expression of uncertainty in measurement (GUM) [5], has been also used (Fig. 4) to complete the uncertainty calculations. This method gives the relation and the influences between each input parameter.

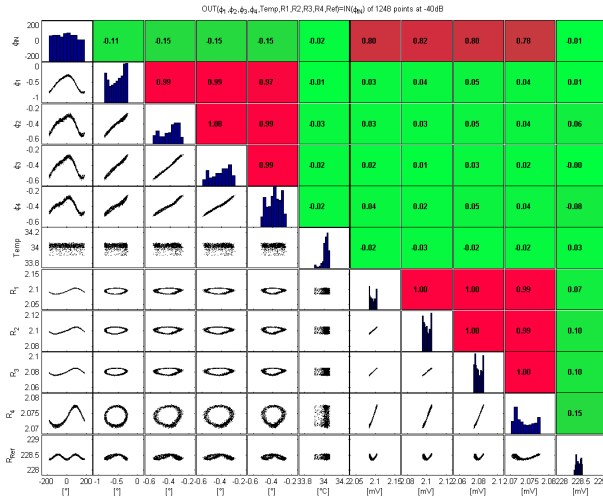

Figure 4: Matrix representation of the various parameters.

The phase input is sent randomly and all the parameters of interest are memorized: the phase, the amplitude of each way, the signal reference level, and the temperature. Then a Matlab^(R) tool is used to represent the data in statistics representation, in diagonal. The left part of the matrix represents the variations of each parameter with one another. The right part of the matrix returns a matrix *R* of Spearman's rank correlation coefficients calculated from an input matrix *X* whose rows are the observations and whose columns are the variables. The matrix is related to the covariance matrix. The coefficient is connected with a color in order to show the weight of the correlation: red is strong, green is weak.

This type of method allows to examine more precisely the influence level of each parameter on the uncertainty.

DYSFUNCTION CHECKING

The TOF system checks the correct operation of the energy measurement.

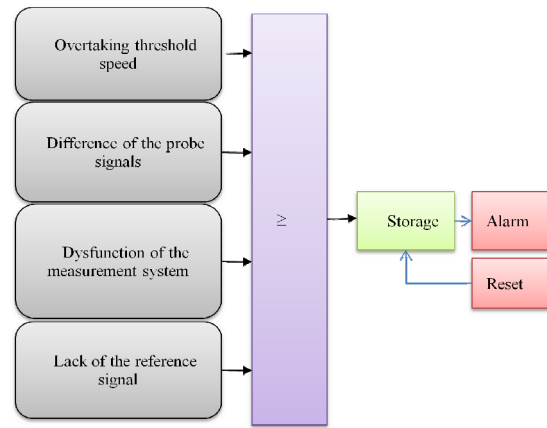

Figure 5: Alarm function.

This checking concerns the threshold speed, the difference of the signal levels, the dysfunction of the measurement and the lack of the reference signal.

CONCLUSIONS

Currently, two TOF systems are realized to be used during the MEBT commissioning in the BTI (Bench of Intermediate Test).

For the beam energy control at the exit of the Linac, and to respect the control requirements, new electronic cards will be developed.

This control implies for the system:

- A quality assurance process
- An Analysis of the Failure Modes and a consideration of these effects
- The consideration of the uncertainties

A test device by remote control is also planned which allows, in operation, to be sure that the measurement system is in good working order.

REFERENCES

- [1] C. Jamet *et al.*, "Phase and amplitude measurement for the SPIRAL2 Accelerator", Proc. DIPAC09, Basel, Switzerland, <http://jacow.org/>.
- [2] W. Le Coz *et al.*, "SPIRAL2 Beam energy measurement", DIPAC11, Hamburg, Germany.
- [3] C. Jamet *et al.*, Beam intensity and energy control for the spiral2 facility, Proc. LINAC2012, Tel-Aviv, Israel, <http://jacow.org/>.
- [4] Agilent Technologies, Signal Source Solutions for Coherent and Phase Stable Multi-Channel Systems, Application note.
- [5] Evaluation of measurement data – Guide to the expression of uncertainty in measurement, JCGM 100:2008.