



**HAL**  
open science

## Measurement and Control of the Beam Intensity for the SPIRAL2 Accelerator

S. Leloir, T. André, B. Ducoudret, C. Jamet, G. Ledu, C. Potier de Courcy

► **To cite this version:**

S. Leloir, T. André, B. Ducoudret, C. Jamet, G. Ledu, et al.. Measurement and Control of the Beam Intensity for the SPIRAL2 Accelerator. 2nd International Beam Instrumentation Conference - IBIC2013, Sep 2013, Oxford, United Kingdom. pp.900-902, 2013. in2p3-00862378

**HAL Id: in2p3-00862378**

**<https://hal.in2p3.fr/in2p3-00862378>**

Submitted on 11 Mar 2014

**HAL** is a multi-disciplinary open access archive for the deposit and dissemination of scientific research documents, whether they are published or not. The documents may come from teaching and research institutions in France or abroad, or from public or private research centers.

L'archive ouverte pluridisciplinaire **HAL**, est destinée au dépôt et à la diffusion de documents scientifiques de niveau recherche, publiés ou non, émanant des établissements d'enseignement et de recherche français ou étrangers, des laboratoires publics ou privés.

# MEASUREMENT AND CONTROL OF THE BEAM INTENSITY FOR THE SPIRAL2 ACCELERATOR

S. Leloir<sup>#</sup>, T. André, B. Ducoudret, C. Jamet, G. Ledu, C. Potier de Courcy, GANIL, Caen, France

## Abstract

The phase 1 of the SPIRAL2 facility is under construction at the national heavy ion accelerator (GANIL, Caen, France). The accelerator including an RFQ and a superconducting LINAC will produce deuteron, proton and heavy ion beams in a wide range of intensities and energies (beam power range: a few 100W to 200kW). The measurements of the beam intensities are ensured by means of several AC and DC Current Transformers (ACCT/DCCT).

These measurements are required for the accelerator tuning and the beam controls for safety requests during the daily operation. The uncertainty has to be taken into account to determine the threshold values. This paper presents the measuring chain description of ACCT/DCCT, the signal processing by integration and the uncertainty studies.

## ACCELERATOR CHARACTERISTICS

SPIRAL2 will produce different beams (protons, deuterons and heavy ions) at very high intensity. Table 1 recalls the main beam characteristics.

Table 1: Beam Specifications

Beam	P	D <sup>+</sup>	Ions
Max. Intensity	5mA	5mA	1mA
Max. Energy	33MeV	20MeV/A	14.5MeV/A
Max. Power	165kW	200kW	48kW

The beam will be chopped so as to reduce the mean intensity while keeping the same peak current. The chopper is necessary in the tuning phases of accelerator in order to increase the beam power progressively.

The duty cycle of the slow chopper ranges are:

- from 1/10000 to 1/2000 at 1Hz
- from 1/2000 to 1/1 at 5Hz

## NON DESTRUCTIVE BEAM INTENSITY MEASUREMENTS

In order to control continuously the intensities and the losses, non-destructive beam intensity measurements are set up along the accelerator [1]:

- at the entrance of the Radio Frequency Quadrupole (RFQ)
- at the entrance and the exit of the LINAC
- at the Beam Dump entrance

<sup>#</sup>leloir@ganil.fr

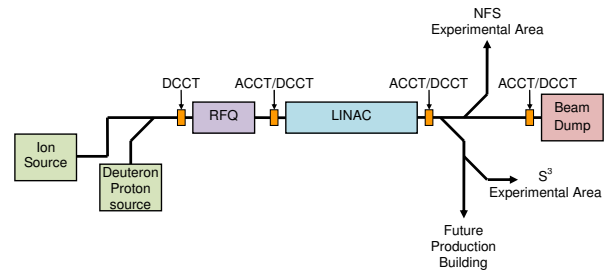

Figure 1: Intensity measurement locations.

The use of two kinds of non destructive measurement chains DCCT (Bergoz NPCT-175-C030-HR) and homemade ACCT is justified by the difference of detection principles and by their complementarities.

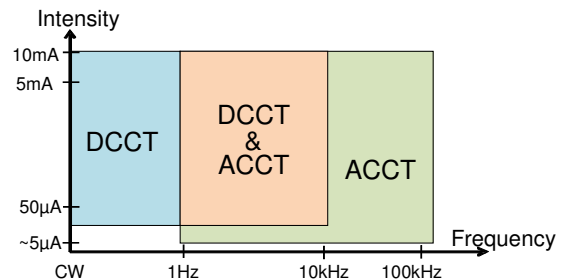

Figure 2: ACCT/DCCT operating range.

The DCCTs measure the intensity of continuous and chopped beams with a slow response time (about 50  $\mu$ s for a bandwidth of 10 kHz). The minimum intensity that can be measured is few 10 $\mu$ A due to the offset level.

The ACCTs are faster with rise times about 1 $\mu$ s and with minimum levels less than 10 $\mu$ A.

The measurements of intensities and transmissions are required for the accelerator tuning (command-control) and the beam controls for safety (Machine Protection System: MPS). The difference of the measured intensities gives the transmission of the MEFT, Linac and HEBT lines.

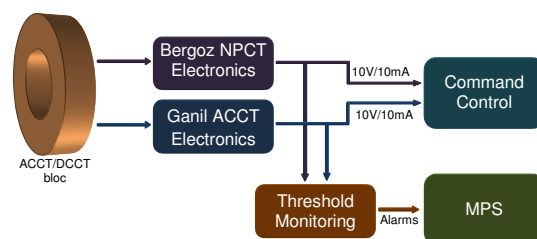

Figure 3: Setup of an ACCT/DCCT chain.

## BEAM CONTROLS

The intensity controls are part of the Machine Protection System (MPS) [2] which ensures the control and the protection of the accelerator. The MPS is divided into two subsystems:

The thermal protection system protects the accelerator against direct beam thermal damage.

The enlarged protection system controls:

- the facility operating range
- the radiation produced by beam losses
- the integrity of beam dump and targets

The MPS receives alarm signals from several diagnostics. Depending on the accelerator mode, when an alarm is active, the MPS system triggers a beam cut.

## ALARM SIGNALS

The mean intensities and losses are compared to maximum allowed intensities i.e. thresholds. Each threshold overrun generates an alarm.

The slow chopper periods (1s or 200ms) and the required response time (<1s) do not enable to use a simple filter to extract the mean intensity.

A digital moving integration over 1s or 200ms allows:

- response times lower than slow chopper period
- response times depending on intensity level excess

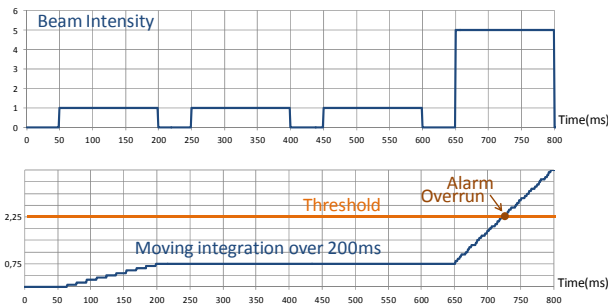

Figure 4: Threshold monitoring by moving integration.

### Integrator Principle

The ACCT or DCCT signal is converted into a pulse frequency. Continually, a counter adds up the pulses and removes the delayed pulses. The delay corresponds to the time interval of integration. This time is equal to a multiple of the chopper period, the counter value is then representative of the input average signal.

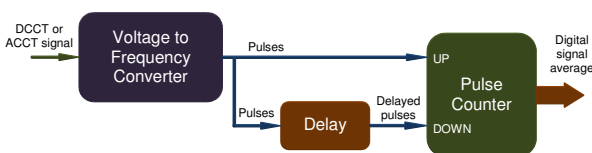

Figure 5: Integrator principle.

### Electronic Monitoring

To generate the alarm signal, the counter starts at the threshold value and its inputs are inverted (count down the pulses and count up the delayed pulses). Therefore, the counter value is equal to the threshold value minus the integrator value.

A negative value of counter is equivalent to the exceeded threshold. In that case, the alarm signal is the sign bit of the counter.

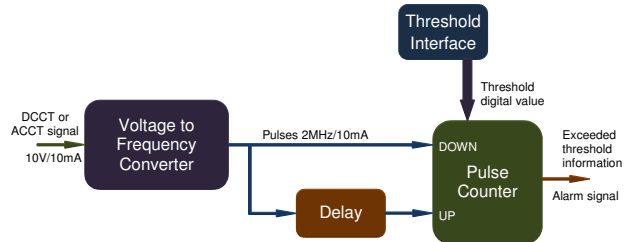

Figure 6: Synoptic of threshold monitoring.

A microcontroller is added to this architecture. It can also perform the counting function and monitor the other thresholds with less reliability but more flexibility. The microcontroller manages the other functions like the communication between the electronics and the command control.

## UNCERTAINTY IN MEASUREMENT

The threshold values must take into account the measurement uncertainty [3]. The influence quantities in the total uncertainty are:

- Offset
- Noise
- External Electromagnetic field
- Linearity and accuracy of the gain
- Temperature drifts (only DCCT)
- Low drop (only ACCT)
- Slow rate
- Time lag between two chains (only efficiency transmission measurement by ACCT)

Tests and measurements were realized to study the standard measurement uncertainties. A test bench was developed to characterize the ACCT and DCCT chains.

### Test Bench

The bench principle is to put ACCT/DCCT under real operating conditions. The beam is simulated by a current in a test spire through the ACCT/DCCT blocs. This current is modulated by a function generator and a current chopper. The output voltages of diagnostics are monitored by a voltmeter synchronized on the function generator. A computer drives the current generator and the voltmeter for automatic characterizations of the ACCT/DCCT.

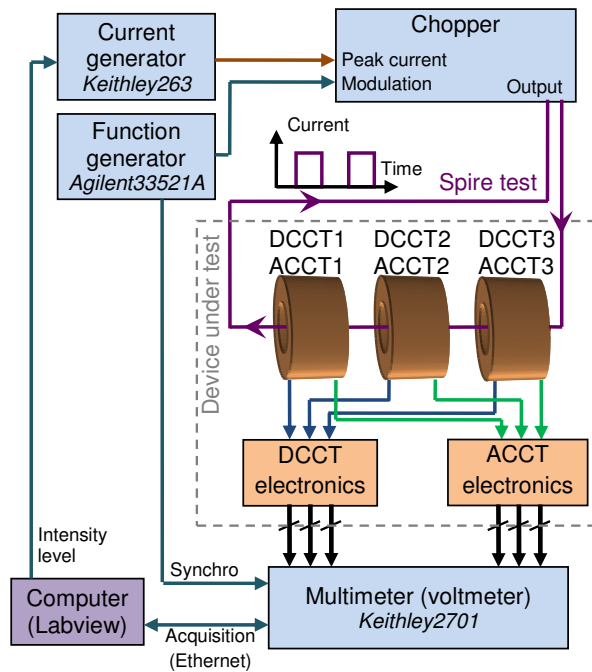

Figure 7: Bench setup.

The linearity and the offset drift versus the room temperature have been quantified with this bench.

### Optimization of ACCT Low Drop

The low drop is the gradual fall of the ACCT signal during a constant pulse beam. The low drop uncertainty is proportional to the pulse duration. A new electronic was developed to reduce the ACCT low frequency up to few 10mHz.

A clamp function is implemented to generate the DC of the ACCT signal. The negative component corresponding to the beam off is set to zero at each chopper period by a digital clamp. The low drop effect is minimized when the clamp is triggered in the middle of the time off.

### Optimization of DCCT Offset

The DCCT offset arises mainly from the temperature of transformers. Under normal conditions, the room temperature varies between 15°C to 31°C. So, the offset can be superior to 100µA.

A study is in progress to stabilize the temperature of the ACCT/DCCT blocs.

### Optimization of External Electromagnetic Field

Three shielding layers (Armco, Mu-metal and copper) protect the sensors from external electromagnetic fields.

A vertical shield plate between AC and DC sensors is installed to minimize the disturbance produced by the DCCT magnetic modulator on the ACCT.

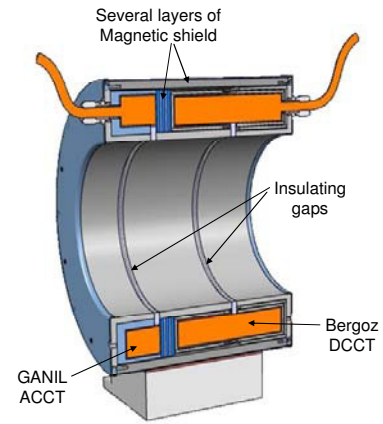

Figure 8: ACCT/DCCT bloc section.

### Statement of the Uncertainties

The next datasheet (Table 2) resumes the uncertainties for ACCT and DCCT.

Table 2: Statement of the Uncertainties

Sources of uncertainty	ACCT	DCCT
Linearity*	0.1%	0.6%
Offset vs. Temperature*	-	In progress
Integrator Offset	0.5µA	0.5µA
External magnetic field max.	5µA	-
Noise	3nA/√Hz	200nA/√Hz
Low drop	2%/s	-
Slew rate	5µs	50µs

\*measured by the GANIL test bench

### CONCLUSIONS

The ACCT/DCCT blocs are made and qualified. The GANIL electronics are in the prototype step. The monitoring threshold system and the DCCT temperature stabilization are being characterized.

The next step consists to measure the uncertainties of the global chain (diagnostic, electronic and integrator) with the Test Bench.

Another step is to improve the system after the Failure Mode and Effect Analysis (FMEA).

The last step will be the manufacturing of the final version of the electronic cards and the re-characterization.

### REFERENCES

- [1] C. Jamet *et al.*, "Injector Diagnostics Overview of SPIRAL2 Accelerator", DIPAC2007, Venice, Italy.
- [2] M-H. Moscatello *et al.*, "Machine Protection System for the SPIRAL2 Facility", IPAC2012, New Orleans, Louisiana, USA.
- [3] C. Jamet *et al.*, "Beam Intensity and Energy Control for the SPIRAL2 Facility", LINAC2012, Tel-Aviv, Israel.