



**HAL**  
open science

## On line beam diagnostics at GANIL

F. Loyer

► **To cite this version:**

F. Loyer. On line beam diagnostics at GANIL. Eleventh International Conference on Cyclotrons and their Applications, Oct 1986, Tokyo, Japan. pp.449-452. in2p3-00997376

**HAL Id: in2p3-00997376**

**<https://hal.in2p3.fr/in2p3-00997376>**

Submitted on 22 Apr 2020

**HAL** is a multi-disciplinary open access archive for the deposit and dissemination of scientific research documents, whether they are published or not. The documents may come from teaching and research institutions in France or abroad, or from public or private research centers.

L'archive ouverte pluridisciplinaire **HAL**, est destinée au dépôt et à la diffusion de documents scientifiques de niveau recherche, publiés ou non, émanant des établissements d'enseignement et de recherche français ou étrangers, des laboratoires publics ou privés.

# GANIL



ON LINE BEAM DIAGNOSTICS  
AT  
GANIL

F. Loyer

GANIL  
A 86.09

October 13-17, 1986 - Tokyo (Japan)

ON LINE BEAM DIAGNOSTICS AT GANIL

F. Loyer  
GANIL, BP 5027, 14021 CAEN Cedex, FRANCE

1. SUMMARY

This paper describes the beam diagnostics set at GANIL in 1986 or being designed at present. After reminding of the control system which allows to use these diagnostics efficiently, we give a brief technical description of any beam diagnostics which are used from the control room to tune and to control the accelerator. Lastly the probe locations along the beam lines and inside the cyclotrons are shown on drawings. This paper exists with few illustrations as a GANIL internal report<sup>1</sup>.

2. BEAM DIAGNOSTICS CONTROL SYSTEM<sup>10, 12</sup>

Any beam diagnostics can be used from the main console. Every beam diagnostic device is controlled:

- either directly by the main control computer via the CAMAC interface and a serial loop (ex : current transformers, position probes),
- or by a CAMAC autonomous controller made with a ROBO or, more recently, a 68K microprocessor. These autonomous controllers are linked to the main computer via the CAMAC interface during the operation or used with a local console during the maintenance (ex : phase and profile monitors).

The operators can use these beam diagnostics:

- either one by one by selecting what they want with a touch-panel, then by using buttons and shaft encoders to control it and TV monitors to display the data (ex : to control the probe position and to read the beam intensity),
- or with programs which achieve sophisticated actions such as (among more 100 of them):
  - \* measuring the beam phase law inside the SSC and setting the trim coil currents to get the good isochronism,
  - \* optimizing the injection or extraction transmission,
  - \* measuring the beam emittance.

A few data may be more convenient in some cases if they are analog. So, these data are sent to the console through an analog multiplexer (SOS) controlled by the control computer via the CAMAC interface. They are displayed on oscilloscopes (ex : beam profiles, beam time structure) or on recorders (beam phase or intensity).

The probe safety against the beam power is provided by a programmable controller whose status can be read by CAMAC.

3 POSITION AND PROFILE MONITORS

In the beam lines

To tune the position and the focus of beam, we have got 50 profile monitors in the beam lines of the accelerator and 60 in the experiment area (fig 3).

These monitors are made with multiwire planes which give the vertical and the horizontal profiles. These wires, made with golden tungsten, 20  $\mu$ m large, are 0.5 or 1 or 1.5 mm distant according to the location. They are directly soldered on a teflon printed circuit. A high voltage ring extracts the secondary electrons<sup>1</sup>.

The electronic unit is made with integration capacitors or with current-to-voltage converters (more sensitive) for every wire followed by an analog multiplexer for every plane. It allows to display the beam profile on the oscilloscopes of the main console via the SOS (Signal Observation System) or to process these profiles with a CAMAC microprocessor.

The main problem is that the wires are fragile and are often destroyed by fusion if the beam power is too high or by atom pulling out if the intensity is too high. So, we are trying to improve them by changing the materials, the size and the tension of wires and by using springs but without hoping much improvement. It is why we are designing an electronic device which automatically reduces the beam intensity when it becomes dangerous for the wires.

Another way which is considered is the use of electrons emitted by the residual gas ionisation and detected by a microchannel plate. The first tests are full of promise<sup>11</sup>.

A second and important utilization of these monitors is the beam emittance measurement. Two methods are used at present<sup>4</sup>:

- by moving a slit in front of a profile monitor, that allows to get the shape of the emittance,
- by computing from three consecutive beam profiles. In this case, we suppose that the beam emittance is elliptic.

4 stations are equipped to measure the beam emittance (fig 3).

These wire monitors are not suited to control the beam position after the tuning because of the beam loss (up to 5 % a monitor) and their fragility. So, we are designing a capacitive position monitor<sup>13</sup>. The first tests have shown that we may expect very good characteristics (60 dB beam intensity range with the same gain, working down to 10 nA, 0.5 mm accurate).

In the SSC's (fig 1)

In each sector, there is a probe which moves through the yoke from the first turn up to the extracted turn. Three probes have a head with a finger which gives the radial beam profile and one has three fingers which estimate the vertical beam position. These heads are cooled directly with water and the small fingers indirectly with beryllium oxide<sup>17</sup>.

The characteristics of the mechanical system are:

- range : 2.5 m
- resolution : 0.5 mm
- maximal speed : 25 mm/s

A small range probe gives the radial profile and position of the last orbits just before the extraction deflector. As measuring with this probe is long, we have developed a multiwire profile monitor which detects the last turns. It allows to adjust the turn separation quickly.

To adjust the beam position in the injection and extraction channels, we use kinds of diaphragms located in front of these channels and also the movable probes

for the extraction. An improvement of this system is necessary because it is not sufficient to know well the beam orbit in the injection and extraction lines, which makes difficult a good tuning without beam loss. We are considering setting up new diaphragms with small fingers to get the radial and vertical position of the beam loss point, and capacitive position probes between injection elements to know the precise beam position at the channel inputs.

#### 4. BEAM CURRENT MONITORS

##### Interceptive probes

In the beam lines, we use the classical Faraday cups, some have been made by NTG (west german manufactory) and some new ones have just been made by GANIL with a permanent magnet (fig 2).

In the SSC's, we use the movable probes to measure the internal beam current, this measurement being right because the magnetic field stops the electron emission. We have a Faraday cup at the SSC center too (fig 1).

Any beam current can be read with current-to-voltage converters. They have two outputs (high and low gains) and a current loop to calibrate them and test the continuity from the target up to the control room. The resolution is limited at about 1 nA by the random leakages in the cooling water circuit.

##### Non interceptive probes :

Though the Faraday cups are very useful to measure the beam intensity with accuracy, in routine we prefer to use the beam current transformers which are not interceptive<sup>13</sup>.

These current transformers were installed along the beam lines last year and will be installed this year at the input of each experiment room (fig 2).

The mechanical assembly has been designed to reduce the different causes of noise. In particular, three shieldings (from inside to outside : aluminium, mu-metal, soft iron) reduce the electromagnetic interference and a suspension cancels the vibration.

The electronic device consists of a current-to-voltage converter and a synchronous detector locked on the low frequency beam pulsation. This pulsation is natural with the PIG source (~200 Hz) or made with a beam chopper when the ECR source is used (530 Hz at present). A current loop allows to calibrate the detector.

The resolution would be less than 1 nA if all the parasitic noises had been cancelled but there are still some left and, in particular, the sounds which disturb the transformer by microphonic effects.

In practice, the resolution is :

- from 2 to 5 nA with the PIG source because there are many parasitic noises which have the same frequency as the source pulsation.

- less than 1 nA or than 5 nA according to the duty cycle of the pulsation with an ECR source.

Researches are in progress to improve these performances.

These transformers have become indispensable to watch the accelerator efficiency because the beam current given by them is displayed all the time. Yet, their accuracy is not sufficient to get an accurate measurement of the SSC efficiency. So, we are designing a differential current transformer which will give the SSC beam loss directly with a resolution better than 1 % of the total beam intensity. We shall be able to get the SSC efficiency with a good accuracy.

#### 5. BUNCH LENGTH MONITORS

##### Electron Emission Probes

Most of the bunch length probes use the secondary electron emission produced by the beam on a target or a wire<sup>14</sup>.

In the beam lines (fig 3) we use a classical Faraday cups made by NTG. The electron current is picked by a high voltage grid, that allows to increase the sensitivity and to make the inductive effect smaller.

The signal is sampled after an amplification (1 GHz bandwidth) to obtain a signal with a cycle frequency of 0.3 Hz (pulsed PIG source) or 29 Hz (continuous ECR source). This low frequency signal is easy to send and to display in the control room via the SOS. Its acquisition by the control computer via the CAMAC interface is going to be set. That will allow to compute the bunch length according to different criteria (at the half height, for 95 % of the pulse area, ...) and to eliminate the subjectivity of a visual measurement.

A new probe was developed last year. It is very sensitive because the target has a trapezoidal shape which increases the electron emission.  $10^3$  ppa is enough to do a good measurement. Its time response is less than 300 ps with the same electronic device as before but improved (2 GHz bandwidth).

Inside the SSC (fig 1) we use a special probe which is set on one of the movable yoke probes. It consists of two kinds of combs which are interlaced.

One of them is connected to the inner conductor of the coaxial cable and is polarized negatively (~500 V) to extract the electrons from itself toward the other comb which is connected to the grounded conductor. This electron emission is not disturbed by the magnetic field because it is parallel to the comb plane.

These probes are mainly used to study the accelerator tuning and to understand its behaviour better but they are more and more used in routine during the tuning time.

With the SSC internal probe, we can measure :

- the injected bunch length to study the SSC phase acceptance,
- the accelerated bunch length to see the effects of the phase compression,
- the central phase on each turn to refine the phase law because this probe is considered as the 16th SSC phase probe (see § 6).

With the beam line probes, we can measure :

- the energy spread to optimize it,
- the correlation between the phase extension and the energy inside the bunch (longitudinal emittance),
- the effect of the buncher. The bunch length measurement on a probe simulating in position the SSC1 center allows to adjust the phase and voltage of the buncher quickly and accurately.

##### X-ray Emission Probe :

A second method consists in detecting with a microchannel plate the Xrays produced by the beam on a thin target. An electronic device records the arrival time of Xrays on a multichannel analyser. The time spectrum obtained on the analyser represents the time structure of the bunch. The time resolution is very good (100 ps about) and the sensitivity is almost without limit.

This probe is located just before the experiment area and is mainly used to verify the time structure of the beam provided to the physicists and to optimize it when that is possible (fig 2).

This probe allows to detect very low intensity beams that the physicists sometimes ask for.

## 5. BEAM CENTRAL PHASE MONITORS

### Description : 5.1.1.1.1

The knowledge of the beam central phase is essential for tuning and controlling the beam at GANIL.

In the beam lines, there are 8 capacitive probes which consist of a cylindrical electrode charged by a high impedance amplifier (fig 2).

In the SSC's there is a set of 15 pairs of plane electrodes charged by 50 ohms and located along a radius between two sectors (fig 1). The bunch length probe set on a movable probe can be used as a 16th central phase probe.

For each probe in the beam lines and for each set of probes in the SSC's, there is an electronic unit which detects the central phase and the amplitude of the beam. This detection is made with two synchronous detectors in quadrature locked on the double frequency of the injector RF. They give the components X and Y of the second harmonic of the probe signal. These detectors are made with analog multipliers. All these units are controlled by a CAMAC microprocessor which is linked to the main computer and to the consoles.

We can make two types of measurements.

- the phase absolute measurements which give the components X and Y of the beam vector by making the difference between the vector with beam and the vector without beam, therefore the phase and amplitude of the beam by computing them.

- the phase relative measurements which give the beam phase variation and the beam intensity versus the time. A delay line is adjusted to make  $Y = 0$  at the initial time and get the phase variation directly from  $Y/X$  and the amplitude from  $X$ .

The actual resolution  $\Delta\theta$  (RF degrees) is sufficient for the GANIL beam. It depends on the beam energy  $W$  (MeV/A) (except in SSC's), on the beam intensity  $I$  (nA) and on the bandwidth  $B$  (Hz) of the measurement signal by following formulas :

$$\text{In the beam lines } : I \cdot \delta\theta = \sqrt{B \cdot W}$$

$$\text{In the SSC's } : I \cdot \delta\theta = 0.3 \sqrt{W}$$

Two examples with a 10 Hz bandwidth :

- in the beam lines, we get a resolution of 0.1 degree with a 100 nA beam at 10 MeV/A,
- in the SSC's, we get a resolution of 1 degree with a beam of 1 nA, that is enough to adjust the SSC phase law.

The offset drift is less than 0.2 degree for the relative measurement and the accuracy is less than 1 degree for the comparative absolute measurement between probes. The true phase absolute measurement with the accelerator RF as reference is very difficult to make and its accuracy is low (5 degrees).

### Use :

These central phase measurements have two uses : the accelerator tuning and, this one made, its controlling.

For the accelerator tuning, we use the phase measurements :

- to tune the phase of the buncher before SSC1 by recovering the same beam phase at the SSC1 input after the buncher is switched on. We rather use the bunch length measurement now (see § 5).

- to adjust the SSC magnetic field topology to obtain the good phase law,

- to recover a good accelerator tuning after a shut-down because the beam phases are used as tuning references,

- to optimize the beam energy by measuring the difference of the beam phase between two probes.

As any shift of the accelerator tuning induces a beam phase shift, we watch the beam phase permanently at the input and the output of each cyclotron to control the tuning. Some parameters are very sensitive (SSC magnetic field and RF level mainly). So, four beam phase lock loops compensate their shift.

- Two loops keep the beam phase difference constant between the SSC output and the SSC input by modifying the SSC magnetic field level.

- One loop keeps the beam phase constant at the SSC1 input by modifying the injector RF level and one at the SSC2 input by modifying the stripper voltage.

These feedback loops are efficient and make the beam very stable and the operation more comfortable. Yet, these loops are rudimentary because they compensate the shifts of all the parameters by modifying one of them only. That may induce a bad tuning after a while. So, they are only a help but they do not replace the operators.

## 7. COUNTING SYSTEM OF BEAM TURNS IN SSC'S

It is not possible to know the number of turns with the movable yoke probes inside SSC2 because the turns overlap one another, and yet, it is necessary to know the number of turns to be able to remake the same tuning of SSC2 every time.

A device has been designed to do that. We detect the beam intensity at the input and output of the SSC from the phase capacitive probes with a fast synchronous detector and a fast numeric oscilloscope. Then, we compute the cross correlation function between these two beam intensities with an apple II. If the beam has a random structure with a large frequency spectrum ( $\sim 3$  MHz), the maximum of this function is obtained for the time of flight  $t$  between these two probes. From  $t$ , we can deduce the right number of turns. The beam random structure is natural with a PIG source and made artificially by modulating the ECH injection line buncher RF level with a noise source when the ECR source is used.

A signal to noise ratio as low as 0.5 or even less allows to get a good result, which is obtained with a 20 nA beam intensity in SSC2.

We also use this system with SSC1 because it is faster (a few seconds) than using the movable probes (about 3 minutes).

Soon, we shall use the internal bunch length probe located at the last turn instead of the output phase probe to be able to compute the number of turns without extracting the beam.

## REFERENCES

1. F. LOYER "Beam diagnostics at GANIL in 1986" - Int. Report GANIL A.86.01
2. R. ARNE, M. VAN DEN BOSSCHE, "A secondary emission multiwire chamber for GANIL heavy ion beam tuning" Proc. of the 8th Int. Conf. on Cyclotrons, Bloomington, sept. 1978.
3. F. LOYER, "Projet de sonde d'extension en phase à émission secondaire d'électrons dans les CSS" Int. Report GANIL BOR/108/CC/12, Sept. 1980.
4. F. LOYER, "Diagnostics de phase centrale à sonde capacitive" Int. Report GANIL 79R/168/CC/22 1979.
5. F. LOYER, J.M. LOYANT, M. PROMÉ, Mechanical Group, "Main Beam Diagnostics for the SSC" Int. Report GANIL BIR/094/CC/15, Sept. 1981.
6. B. BRU "Méthodes de mesure d'émission pour les lignes de transfert du GANIL", Int. Report GANIL BOR/047/TF/02, 1980.
7. F. LOYER et al., "Main Beam Diagnostics at GANIL" Proc. of the 9th Int. Conf. on Cyclotrons, Caen (FRANCE), Sept 81

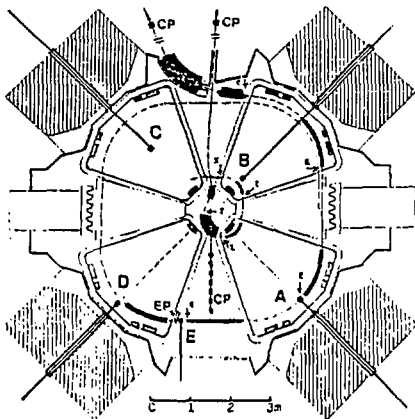

movable Probes  
**A B E** : radial Position  
**D** : radial Position + Bunch Length  
**C** : radial and vertical Position  
**EP** : Extraction Profile Multiwire Probe

Figure 1

8. F. LOYER et al, "Diagnostics de faisceau Mesure de la phase centrale", *Int. Report GANIL 83R/010/CC/01*, 1983.

9. J. M. LOYANT, F. LOYER, J. SAURET et al, "The Computerized Beam Phase Measurement System at GANIL", *Proc. of the Conf. "Computing in Accelerator Design and Operation"*, West-Berlin, 1983.

10. GANIL operation Group and Computer Control Group "GANIL beam setting methods using on-line computer codes", *1st Conf. on Computing in Accelerator Design and Operation* - September 1983.

11. A. CHARENT, F. LOYER, J. SAURET, "Beam Tuning and Stabilization using Beam Phase Measurements at GANIL", *Proceedings of the 10th Int. Conf. on Cyclotrons* East Lansing US, 1984.

12. GANIL Control Group and Operation Group "The operation of the GANIL Control System" *Proc. of the 10th Int. Conf. on cyclotrons* - East Lansing - 1984

13. F. LOYER, Th. ANDRE, B. DUCQUOIRET, J. P. RATAUD, "New Beam Diagnostics at GANIL : Very Sensitive Current Transformers in Beam Lines and Counting System of Beam Turns in Cyclotrons" *Proc. of the 1995 Particle Accelerator Conference* Vancouver - CANADA

14. B. LAURIE, "Sonde non destructive d'injection pour CSS1, projet d'un detecteur a ionisation du gaz residue" *Int. Report GANIL/R/29.36/1*, mars 86.

15. F. LOYER, Cl. DOUTRESSOLLES, B. DUCQUOIRET, J.P. RATAUD, "Diagnostics de faisceau - Projet de sonde de position capacitive" *Int. Report GANIL/R/507.36* to be published.

CP : Central Phase Probes      I : Injection Diaphragms  
 E : Extraction Diaphragms

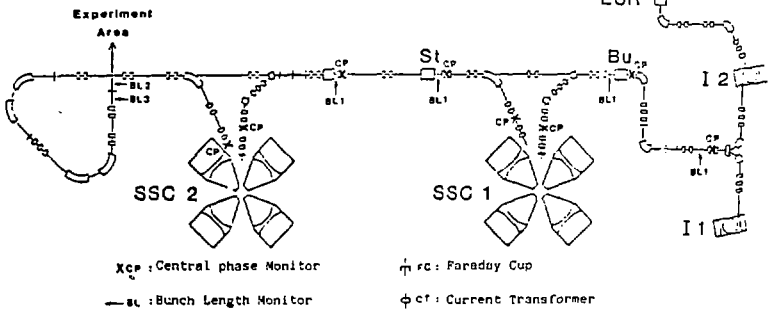

Figure 2

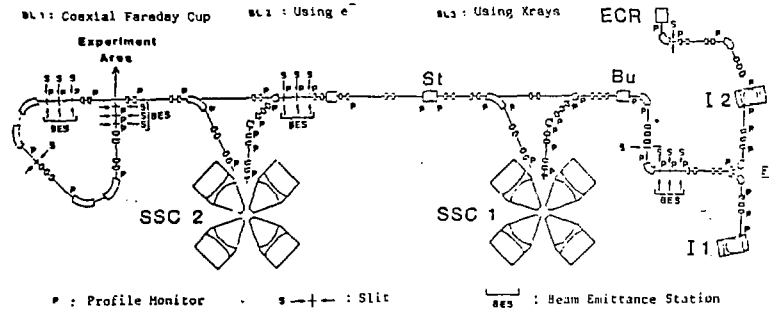

Figure 3

BL1 : Coaxial Faraday Cup      BL2 : Using e<sup>-</sup>      BL3 : Using Xrays      P : Profile Monitor      S : Slit      SES : Beam Emittance Station